

TRU-TURF
ROLLING PERFECTION

OWNERS MANUAL



RE50 GOLF GREENS ROLLER

Original Instructions

For rollers from serial number: **RE50-0402**

EU Authorised Representative:

VeriSafe Compliance Ltd.

77 Lower Camden St

Dublin

DO2 XE80

Ireland

Original Instructions

The products detailed in this manual conform to the following standards:

Machinery Directive 2006/42/EC, EMC Directive 2014/30/EU & EN ISO 4254-1:2015

CE Declaration available at www.truturf.com

Manual Revision: J

Released: 17/07/2024

For rollers from serial number: RE50-0402 onwards.

Table of Contents

1. Machine Information Record
2. Specifications
3. Safety Information
4. Warranty
5. Pre-Operation Checklist
6. Standard Operation Procedures
7. Transport Lifting
8. Points to Remember
9. Maintenance Schedule
10. Maintenance
11. Safety and Instructional Decals
12. Operating Positions
13. Assembly, Cover, Electric
14. Assembly, Body
15. Assembly, Drive Unit
16. Assembly, Electric Belt Drive
17. Pulley Alignment
18. Drive Belt Tensioning Instructions
19. Assembly, Flex Tube Drive Roller
20. Assembly, Flex Belt Drive Roller
21. Assembly, Steering - Overlapping Heads
22. Assembly, Front Smoothing Head
23. Assembly, Rear Smoothing Head
24. Assembly, Nodule Sweeper, (Short)
25. Assembly, Nodule Sweeper, (Long)
26. Connecting Rods
27. Assembly, Electric Joystick
28. Assembly, Trailer Frame
29. Assembly, Jockey Post
30. Assembly, Trailer Hub
31. Assembly, Seat
32. Options: Kit
33. Harness Loom
34. Motor Controller Fault Codes
35. Troubleshooting: Belts
36. Troubleshooting: Roller

Separate electric motor Owner's Manual can be downloaded from www.truturf.com

Machine Information Record

Congratulations on your investment in the RE50 Golf Greens Roller and your move to smoother, faster, more consistent putting greens.

The following operation and maintenance manual has been prepared for use with the RE50 Golf Greens Roller.

It is intended as a guide and supplemental updates to the manual may take place at a future date, without prior notice. For the latest information visit www.truturf.com.

This machine is engineered to be simple to operate and easy to maintain.

If you have any questions or concerns that this manual does not address, please feel free to contact your distributor or email technicalsupport@truturf.com

Distributor Information

Name: _____

Address: _____

Telephone: _____

Fax: _____

Email: _____

Machine Information

Model. RE50 Golf Green Roller

Serial No. _____

Engine No. _____

Transmission No. _____

Purchase Date No. _____



Each page contains a *Table of Contents* hyperlink, lower centre of page.



Specifications

Motor Type Watts Engine Cover	48V AC Electric 2500 W - 48V Fully enclosed
Battery	Lithium - Standard, Lead Acid- Optional
Transmission Manufacturer Type	Falk Ultramite Double reduction helical
Drive Train	Toothed belt
Drive Roller	Rubber coated, non-stick. Flexible, contour following
Direction Control	Fingertip switch
Speed Control	Progressive foot pedal movement.
Operating Speed	0-9 mph (0-15kph)
Steering	Light load joystick
Seat	Premium UV protected, with adjustable armrests

Trailer	Integrated, heavy duty. Quick and easy transition from transport to rolling position.
Drawbar Drop Down Leg Lifting Weight	Ball hitch Quick release 25lbs (11kg)
Ground Pressure (Footprint)	3.8 psi (26 kPa)
Smoothing Heads	Dual rolling heads, with overlapping patented offset rollers.
Rolling Width (Swath)	50", (1270mm)
Weight, (no batteries)	765lb (348kg)
Roller Cleaning	Adjustable nodules
Tires	18 x 6.50 x 4. 4 ply
Brake - Park	Handbrake. Drum style
Lighting	LED -Standard
Warranty	2 years - Limited manufacturer's warranty



Safety Information

Safety is of the utmost importance when operating turf equipment.

To ensure safe operation of the RE50 Golf Greens Roller, please follow the following safety guidelines.

- Always make a pre-operation inspection before you start rolling. If this procedure is not carried out, damage to property or personnel may occur.
- Keep children, pets and inexperienced personnel away from the machine. This machine should only be operated by **trained** and **skilled personnel** - check with your supervisor if you are unsure.
- Know how to stop the machine when in motion. Read and understand manufacturers manual, as supplied.
- Never permit **inexperienced operators** to use the machine. This machine requires certain knowledge and expertise to operate it; you must be a trained person to use this machine. Unskilled persons can harm themselves and others if they operate this machine.
- When transporting the roller or carrying out maintenance, make sure the trailer lockdown mechanism is secured by the locking pin to prevent premature release of the catch.
- If the trailer catch is not correctly engaged while towing and releases accidentally, the front of the roller can drop and dig into the ground, causing the machine to move dangerously in any direction causing bodily injury and result in damage to the drive roller and other components.
- When the roller is running, always keep hands and loose clothing away from rotating shafts, **chains**, belts and sprockets in the transmission area.
- It is recommended to wear appropriate person protection equipment, (ppe), as per local laws. These may include hearing protection, eyes and appropriate closed shoes and clothing ppe. Environmental conditions should also be taken into consideration.



Safety Information

- If hair, clothing, or loose objects become entangled on a rotating shaft, serious bodily injury could occur. Always stop engine before opening safety cover.
- Never ride on the machine when machine is being towed.

Operator: remember it is your responsibility to be aware of your surroundings.

To avoid accidents, think safe and operate safe.



Safety Information

IMPORTANT EU MACHINERY DIRECTIVE INFORMATION

SAFETY WARNINGS



Read Operator's Manual.

Only personnel that have read and fully understood the Operator's Manual should operate this equipment.



Keep Bystanders Away.

The operator should ensure that bystanders are not in the immediate vicinity of the machine when it is in use.



Machine Rollover.

Do not use this machine on slopes greater than 10 degrees.



Hearing Protection.

Hearing protection to be worn whilst operating this machine.

Safety Information

IMPORTANT EU MACHINERY DIRECTIVE INFORMATION

SAFETY WARNINGS

SOUND AND VIBRATION LEVELS

The sound and whole body/hand/arm vibration levels are shown below. Please take note of the levels and determine appropriate operator actions, (wearing hearing protection and/or limiting the time of use when operating the machinery).

Sound Levels	
Measured Sound Pressure – LpA dB(A)	Guaranteed Sound Pressure – LwA dB(A)
69	<70

Vibration Levels			
	Measured value (m/s²)	Time to reach Exposure Action Value	Time to reach Exposure Limit Value
Hand/Arm	<1.5	n/a	n/a
Whole Body	1.1	1hr50min	9hr46min

Readings taken at full power

Warranty

Conditions and Products Covered

Tru-Turf warrant your Tru-Turf Roller to be free from defects in materials or workmanship for two years or 1550 operational hours*, whichever occurs first.

This warranty is applicable to all products. Where a warrantable condition exists, we will repair the product at no cost to you including diagnostics, labor, and parts. This warranty begins on the date the product is delivered to the original retail purchaser.

*Product to be equipped with an operating hour meter fitted.

Claiming Warranty Service

You are responsible for notifying the products distributor or authorized products dealer from whom you purchased the product as soon as you believe a warrantable condition exists. If you need help locating a products distributor or authorized dealer, or if you have questions regarding your warranty rights or responsibilities, you may contact us at:

Tru-Turf Service Department

Tru-Turf Pty Ltd

16/6 Energy Circuit, Robina

Queensland 4221, Australia

PH+61 7 5594 7199

E-mail: technicalsupport@truturf.com.

Owner Responsibilities

- As the product owner, you are responsible for required maintenance and adjustments stated in your operator's manual. Failure to perform required maintenance and adjustments can be grounds for disallowing a warranty claim.



Warranty

Items and Conditions Not Covered

Not all product failures or malfunctions that occur during the warranty period are defects in materials or workmanship. This warranty does not cover the following:

- Product failures which result from the use of non- Tru-Turf replacement parts, or from installation and use of add-on, or modified non-Tru-Turf branded accessories and products.
- Product failures which result from failure to perform recommended maintenance and/or adjustments. Failure to properly maintain your Tru-Turf roller per the Recommended Maintenance listed in the Operator's Manual can result in claims for warranty being denied.
- Product failures which result from operating the Product in an abusive, negligent, or reckless manner.
- Parts subject to consumption through use unless found to be defective. Examples of parts which are consumed, or used up, during normal Product operation include, but are not limited to, brakes pads and linings, slicers, spiker tines, tires, filters, belts, springs, sprockets, chains, bearings and pulleys.
- Failures caused by outside influence. Items considered to be outside influence include, but are not limited to, weather, storage practices, contamination, use of unapproved lubricants or additives, etc.
- Normal noise, vibration, wear and tear, and deterioration.
- Normal "wear and tear" includes, but is not limited to, damage to seats due to wear or abrasion, worn painted surfaces or scratched decals.

Warranty

- Specific component parts supplied to Tru-Turf by OEM suppliers are covered by that supplier's Warranty. These parts and components include but are not limited to, Eaton Transmissions, Honda Engines, Sevcon Controllers, Foot Pedal & Trailer Arm Struts, Curtis Controllers & Electronic Foot Pedals, Toggle Switch, Rexnord Gearboxes & Electric Motors, Seats, Drive Rollers, Hour Meter, Rod Ends, Lights, Hood, Transmission Cover, Fan, Rubber Coupling.

Parts

Parts scheduled for replacement as required maintenance are warranted for the period up to the scheduled replacement time for that part. Parts replaced under this warranty are covered for the duration of the original product warranty and the removed parts become the property of Tru-Turf. Tru-Turf will make the final decision whether to repair any existing part or assembly or replace it. Tru-Turf may use remanufactured parts for warranty repairs.

Note Regarding Deep Cycle Battery Warranty:

- Deep cycle batteries have a specified total number of kilowatt-hours they can deliver during their lifetime. Operating, recharging, and maintenance techniques can extend or reduce total battery life. As the batteries in this product are consumed, the amount of useful work between charging intervals will slowly decrease until the battery is completely worn out.
- Replacement of worn-out batteries, due to normal consumption, is the responsibility of the product owner. Battery replacement may be required during the normal product warranty period at owner's expense.

Maintenance is at Owner's Expense

Maintenance of your Tru-Turf roller is to be conducted as per the owner's manual for your Tru-Turf product at the owner's expense.

Warranty

General Conditions

Repair by an Authorized Tru-Turf Distributor or Dealer is your sole remedy under this warranty.

Tru-Turf is not liable for indirect, incidental or consequential damages in connection with the use of the Tru-Turf Products covered by this warranty, including any cost or expense of providing substitute equipment or service during reasonable periods of malfunction or non-use pending completion of repairs under this warranty. Except for the Emissions warranty referenced below, if applicable, there is no other express warranty.

All implied warranties of merchantability and fitness for use are limited to the duration of this express warranty. Some states/ countries do not allow exclusions of incidental or consequential damages, or limitations on how long an implied warranty lasts, so the above exclusions and limitations may not apply to you.

This warranty gives you specific legal rights, and you may also have other rights which vary from state to state and country to country.



Pre-Operation Checklist

- Check that the batteries are fully charged.
- Ensure steering joystick has no looseness.
- Check that foot pedal depresses under normal foot pressure.
- Ensure that the draw bar locking catch mechanism is securely locked to the main draw bar and the safety pin is fitted when trailing the roller.
- Check and tighten grub screws fitted to the end bearing lock rings on the rubber coated drive roller and the spiker shaft bearings, (if fitted), and pivot bearings on each smoothing head.
- Lightly grease bearings fitted to drive roller, spiker shaft, (if fitted), and smoothing head pivot bearings. Replace plastic caps if missing.
- Oil rod ends, sparingly.
- Check tire pressure for proper operating pressure (18-24psi). Do not over inflate.
- Pre-check all nuts, bolts, grub screws for tightness prior to operating machine.
- Understand the operating procedures and the controls before operating.
- Ensure you check with the battery manufacturer for service and care instructions of your batteries



Standard Operation Procedures

1. Inspect and check that the roller is serviceable prior to departing from the workshop. Ensure the batteries are fully charged.
2. Use a suitable towing vehicle to move the roller from green to green.
3. Maximum recommended towing speed would be equal to a motorized golf buggy, i.e., approximately 10-12mph/ 19-19kph. Towing at excess speed or across rough terrain may cause damage to the machine and trailer.
4. When approaching the green do not tow the roller onto the green to set up, put the roller on the fringe of the green. Put trailer in the up position, switch on the roller and drive it onto the green.
5. Greens can be rolled in any direction; take care to ensure there are no crease lines produced on the surface.
6. It is recommended that you place the smoothing head rollers on the high side of the green when rolling. This increases the weight onto the rubber drive roller and creates better traction, it also reduces slipping or spinning of the drive roller on the green, depending on the operator's ability.
7. To drive, switch the key to the **ON** position. Select the direction of travel with the 2-way switch that is fitted on the top of the joystick. To travel left push the switch to the left, to travel to the right press the switch to the right. After selecting the direction of travel depress the foot pedal down until you have reached your desired operating speed. Changing directions, can be done on the fly. The roller will gently come to a stop under regenerative braking and then gently take off in the opposite direction until it reaches the chosen speed or full speed. The other method of operation is to use the accelerator pedal to slow down to a stop, change direction with the switch then accelerate off in the opposite direction. To stop, take your foot off the foot pedal and the machine will automatically come to a stop.
8. Adjusting position of the accelerator pedal:
 - a) Loosen the two bolts located at the rear outer corners of the foot pedal assembly, do not fully remove the bolts.
 - b) Slide the foot pedal assembly towards the front or rear until you find the most comfortable position to suit your leg and foot.
 - c) Re-tighten the two bolts.

Standard Operation Procedures

9. The correct procedure for rolling the green is:
- a) Select the correct direction to roll the green, remember this roller can roll the greens in all directions.
 - b) Start on one side of the green and work your way across the green in a zigzag fashion, slightly overlapping each lap you roll: this makes sure you don't miss any part of the green and all of the green is rolled. Avoid coming back across the green to roll missed areas if possible. You should be able to complete the rolling of 18 greens in the same time or quicker than by mowing, using a triplex mower on a single charge.
10. When rolling of the green is completed, move the roller onto the fringe, switch off the ignition, lock the trailer into the towing position, connect it to the towing vehicle then move off to the next green to be rolled.
11. When using the pin hitch style drawbar, the following 3 points must be adhered to.
- a) Ensure that the hole size in the tow hitch fitted to the towing vehicle is at least 3/8" (10mm) larger in diameter than the pin size fitted on the roller draw bar hitch.
 - b) When towing forwards or reversing, be sure that the roller is not put into a jack-knifed position as damage to the pin hitch will occur.
- c) Do not cross excessively steep hills or dips where the tow hitch pin may gouge the turf and damage the drive roller.
12. Keep the roller on the greens surface. It is not necessary to roll onto the collars or fringes.
13. The operator needs to become familiar with the timing required to stop and the distance required to do so at the speed being travelled, remembering that the roller is quite heavy.
14. There is a park brake fitted to the roller. This is to be used only in an emergency or when parking or leaving the machine on an incline. The park brake should not be used in the normal operation of the roller.

Do not put the trailer down into the towing position on the green; damage may occur to the green from the roller tires and body.



Standard Operation Procedures

Park Brake

The park brake lever operates on an over-centre principal.

To engage the park brake, pull the park brake lever fully up and back.

The park brake lever will remain in this **on** position.

To disengage the park brake, push the park brake lever fully forward and down.

The park brake lever will remain in this **off** position.

Important: Always operate the roller with the park brake off!

Caution: Do not operate the roller with the park brake engaged as this will damage park brake components.

When stopping and before getting off the machine always apply the Park Brake.

Towing

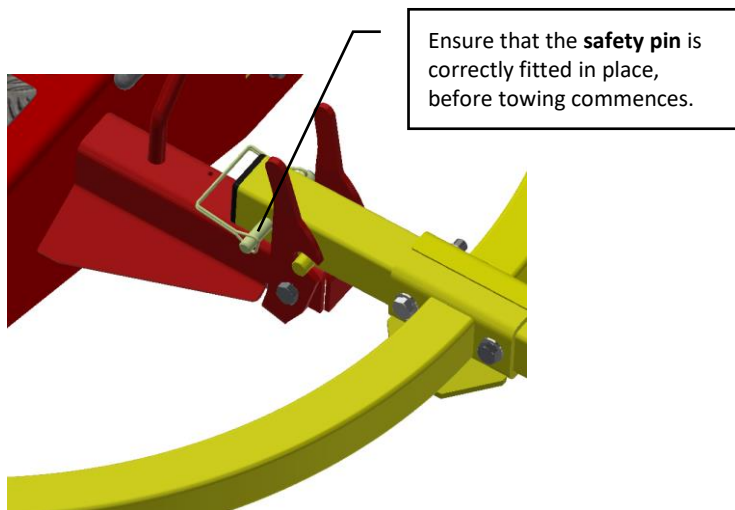

Transport lifting

WARNING: The lift points shown in the diagram, **must only** be used to lift the machine to carry out transport lifting. It is not permitted to carry out maintenance whilst the roller is hanging from the slings.

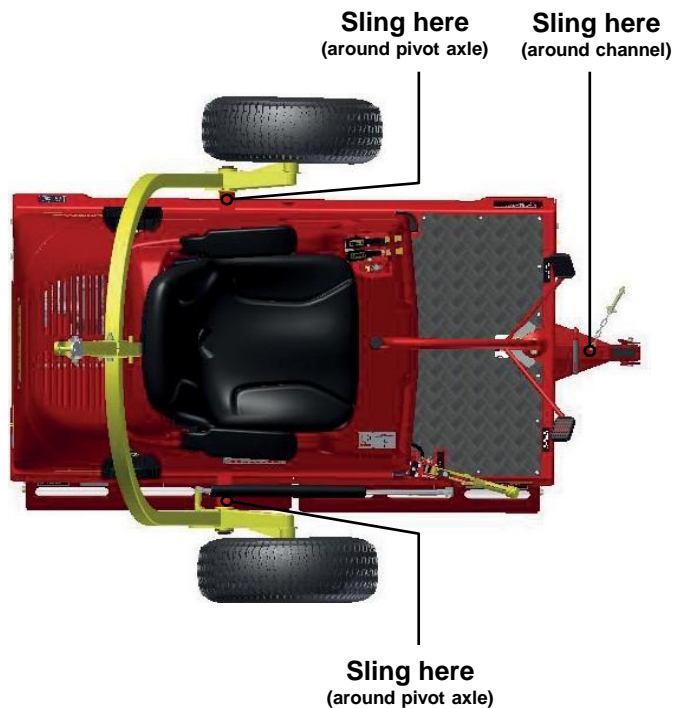

Points to Remember

- Ensure batteries are fully charged.
- Make sure the roller is serviceable before rolling.
- Start rolling from the fringe of the green.
- Pick a point on the other side of the green to roll to.
- Do not look at the green close to the roller, it makes it difficult to steer the roller straight. Look well ahead.
- Use 1/2 throttle until you are proficient at operating the roller.
- Once you choose your rolling line hold the joystick steady, correcting direction gently as required.
- Move the steering joystick a little at a time to change direction; excessive movement of the joystick makes it difficult to maintain a straight line.
- Roll in straight lines.
- Move off the green when rolling is complete before putting the trailer in the down position.
- Extra effort maybe required to raise the roller off the

ground into its towing position. An optional extension bar is available for purchase to extend the drawbar length. Once fitted, it is stored on the drawbar using the spring clip. This extra length added the drawbar gives the operator more mechanical advantage, making it easier to raise the roller into its towing position.



Maintenance Schedule

Description	Pre-Delivery	Pre-Operating	Monthly	12 Monthly
Check tires max 24 psi	√	√		
Check smoothing roller bearing	√	√	√	
Check drive roller bearings	√	√	√	
Check for loose nuts and bolts	√	√		
Renew smoothing roller bearings	*			√
Renew drive roller bearings	*			√
Replace trailer strut	*			as required
Check drive belts			√	√

Ongoing Maintenance, Lubricant and Replacement Schedule (See chart).

Note. Areas indicated with a * need to be changed when defective or as required. This may be before the recommended replacement schedule.

Please replace all parts, as necessary.

Maintenance

Safety

You must always employ safe working practices when performing any assembly or service tasks on the machine.

For carrying out service, the trailer must be secured in the towing position. The roller can then be raised by either employing car ramps or a suitable motor vehicle hoist. The trailer wheels must be secured to prevent movement.

Important: If maintenance is carried out correctly, there is no need to crawl under the roller machine at any time. All maintenance can be done by reaching from the outside.

Raising and lowering the engine cover.

The key switch must be turned off before performing this procedure. Lift the front center of the cover up and carefully tip it backwards until it reaches the travel limit. To lower the transmission cover, release by pulling the cover towards you a few degrees, open the cover back fully, then pull the cover forwards until it closes. Be sure that the cover sits within the rubber rests correctly.

Storing

It is important to store this roller in the towing position. This ensures the trailer gas strut is in the closed position, protecting the shaft from the elements which, if damaged, would accelerate seal wear.

Testing Park Brake

Stop the machine safely on level ground and engage the park brake.

Switch off and dismount from the machine.

Try to push the machine manually.

The park brake must prevent machine from moving. If the machine moves, the parking brake requires adjusting.

Adjusting Park Brake

To adjust the park brake, rotate the knob at the end of the park brake lever in a clockwise direction, when looking down at the lever.

Maintenance

Service of the drive belt system

- Replacement - Some toothed belts look alike, but they are not. Only use the belt and sprockets recommended as per the correct spare parts number. Wrong pitch drive belts fitted will cause excessive sprocket wear and possible drive failure.
- Tension the drive belt by tensioning the idler pulley that depresses onto the back of the belt by loosening the 2 bolts holding the bracket in position, tighten the bolt on the end of the bracket until you can only depress the belt in 1/4" when depressing midway between the 2 sprockets. When this is correct re-tighten the 2 bolts again that hold the bracket onto the body. Be sure that the idler wheel is square to the toothed belt (see [Pulley Alignment](#)).

Service of smoothing roller bearings

- Whilst the roller is in the trailer-down position, check operational smoothness of the bearings fitted to each smoothing roller by rotating the rollers by hand. If bearing tightness, roughness or excessive looseness is detected,

replace the faulty bearings.

- If bearings are faulty:
 - (a) Remove the complete smoothing head unit assembly from the machine, undo the four swivel mount bolts on the upper body and disconnect the steering rod, wheel the roller away until the total head assembly is exposed to work on.
 - (b) Remove roller shaft bolts from end plates, remove rollers from the heads.
 - (c) Fit new bearings, replace rollers into the heads, lubricate shaft bolts with an anti-seize compound before installing them. Tighten securely and ensure rollers rotate freely when fully tightened.
 - (d) If the connecting rods are removed or lengths altered ensure they are correctly adjusted so that the two heads are parallel to each other when in the straight-ahead position. Adjust if necessary.



Maintenance

Changing transmission oil

Refer to the manufacturer's maintenance instructions.

This can be found by following the link below, or the Tru-Turf web page.

Transmission Manufacturer: [Rexnord_203UCBN2A-8.0A1B](#)

Batteries

Ensure batteries are fully charged before going to the greens.

To maximize the service life of the batteries, it is best practice to charge the batteries before they are totally flat, if you were to continually flatten the batteries and then recharge, the life of the batteries will be reduced. Charging can be done at any stage of use; the batteries do not have a memory.

When charging the machine for the first time, or if the batteries have been allowed to become considerably discharged, initially there will be a noticeable amount of heat emitted by the charger, mains cable and the battery charging cables. This is normal.

Winterize Batteries

For Trojan lithium-ion batteries: see “Storage and shipping of lithium-ion batteries”

[Trojan lithium-ion batteries FAQ](#)

For Relion batteries: see “How do I prep my lithium battery for off-season storage?”

[Relion FAQs](#)

For Trojan wet cell batteries: see *Storage*

[Trojan wet cell batteries](#)

FAQ

Tru-Turf: [Tru-Turf FAQs](#)

Maintenance

WARNING! Pressurized gas

- This roller makes use of pressurised gas cylinders.
- **Do not** try to open or re-gas pressurized cylinder.
- Replace with new when faulty.



Safety and Instructional Decals

Safety decals and instructions are easily visible to the operator and are located near any area of potential danger. Replace any decal that is damaged or missing.



R9086 CHAIN/BELT PINCH POINT



E8858 DRAWBAR LIFTING

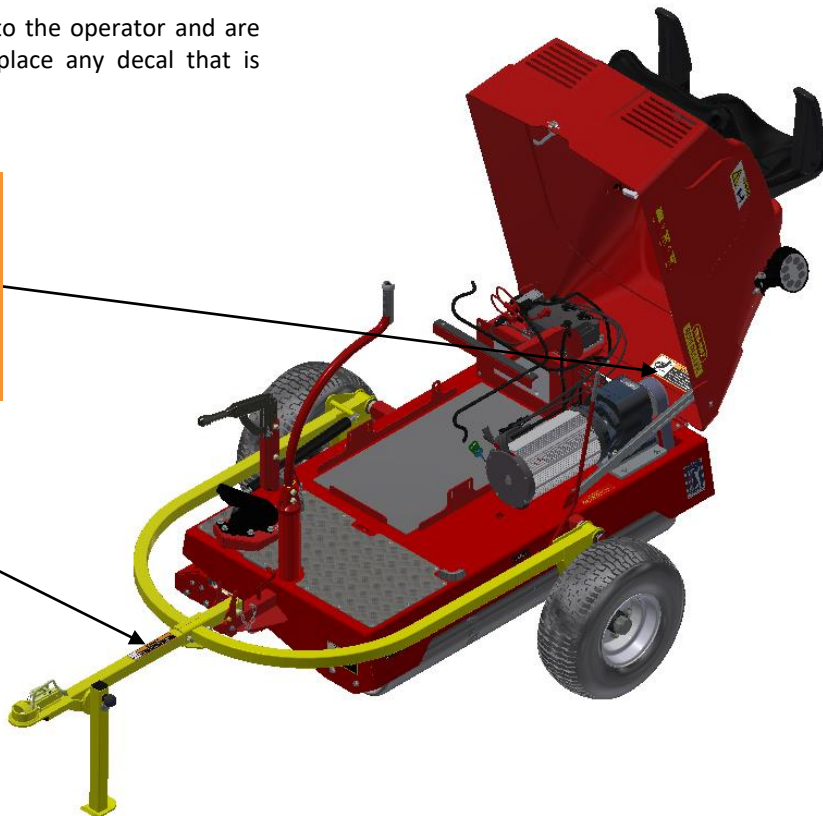

Safety and Instructional Decals

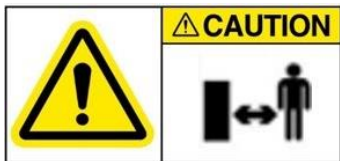
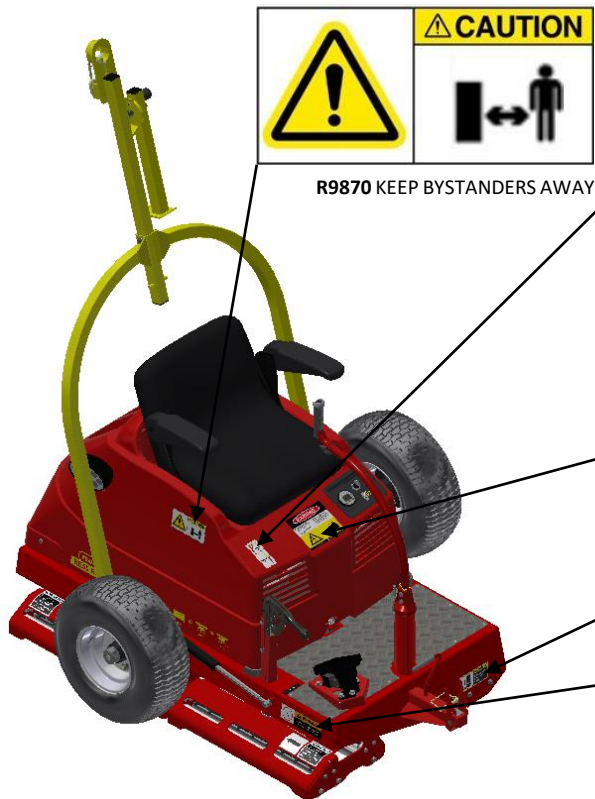

R9870 KEEP BYSTANDERS AWAY

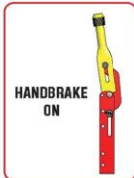

E7068 HANDBRAKE INSTRUCTIONS



E7075 ELECTRIC MAIN



R9087 PINCH POINT



R8452 STRUT REQUIRED

Safety and Instructional Decals

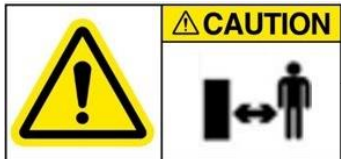

R9870 KEEP BYSTANDERS AWAY



E8858 DRAWBAR LIFTING



RS2210 - Machine ID Plate. (Note: This is not a spare part and will come attached from manufacturer).



R8848 BATTERY SOURCE



R9087 PINCH POINT

Operating Positions



Towing position

Rolling position



Assembly, Cover, Electric

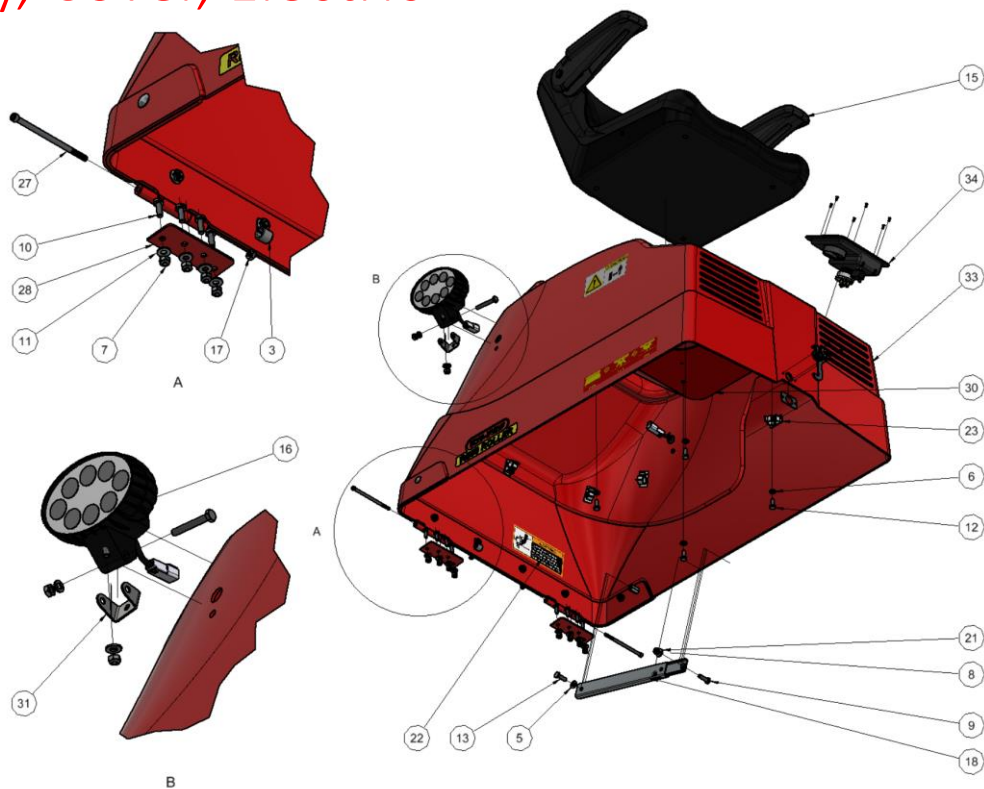

PART NUMBER: RS2220
REVISION: L

Assembly, Cover, Electric

RS2220 PARTS LIST						
ITEM	QTY	PART NUMBER	DESCRIPTION	ITEM	QTY	DESCRIPTION
1	1	E7068	DECAL, HAND BRAKE OPERATION INSTRUCTION	18	1	R8776 LATCH STAY SUPPORT
2	1	E7075	DECAL, ELECTRIC - MAIN	19	1	R8848 DECAL, ELECTRIC CHARGE
3	1	E7076	CLIP, P, 10 mm	20	2	R8850 DECAL, MODEL ATTACHMENTS
4	1	R6057	DECAL, TRU-TURF LOGO	21	1	R8993 WASHER, ACETAL, WHITE (219.3x8.0x2.7)
5	2	R8046	5/16" X 3/4" FLAT WASHER, ZP	22	1	R9086 DECAL, PINCH POINT - FINGERS
6	4	R8051	5/16" SPRING WASHER, ZP	23	6	R9167 CABLE HOLDER, 1-7/16" L x 3/4" W x 1-1/4" H
7	8	R8053	1/4" UNF NYLOC NUT, ZP	24	2	R9594 5/32" X 13mm RIVET, ALUMINIUM
8	1	R8054	5/16" UNF NYLOC NUT, ZP	25	2	R9870 DECAL, KEEP BYSTANDERS AWAY
9	1	R8064	5/16" UNF X 1" SET SCREW, ZP	26	1	R9916 MOUNT PLATE, LATCH
10	8	R8137	1/4" UNF X 3/4" SET SCREW, ZP	27	2	R9974 1/4" UNC X 4-1/2" SOCKET HEAD CAP SCREW, ZP
11	8	R8140	1/4" X 5/8" X 0.065" FLAT WASHER, ZP	28	2	RS2121 WELDMENT, HINGE, LOWER
12	4	R8177	5/16" UNF X 3/4" SET SCREW, ZP	29	1	RS2141 DECAL, RESULTS THROUGH DESIGN...
13	1	R8242	M8 X 25 SET SCREW, ZP	30	1	RS2185 BASE PLATE, SEAT SUPPORT
14	1	R8343	LATCH, PULL-AND-LOCK HOOK (1-250) - DIRAK	31	2	RS2186 BRACKET, LIGHT MOUNT
15	1	R8365	MILSCO ALL PLASTIC SEAT	32	2	RS2211 DECAL, MODEL ID
16	2	R8455	LIGHT, LED, OVAL	33	1	RS2221 SUB-ASSEMBLY, COVER, ELECTRIC
17	2	R8519	1/4" UNC NYLOC NUT, (TYPE T), ZP	34	1	RS2290 ASSEMBLY, SWITCH CONTROLLER BOX



Assembly, Cover, Electric

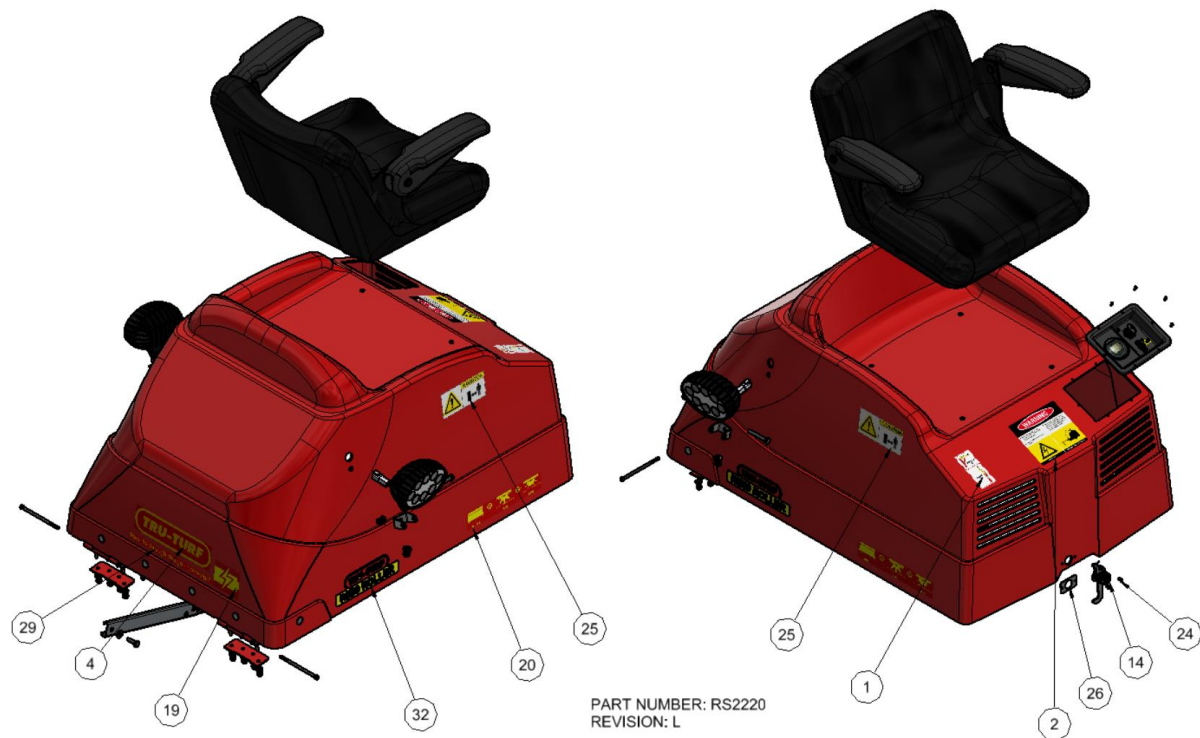

Assembly, Body

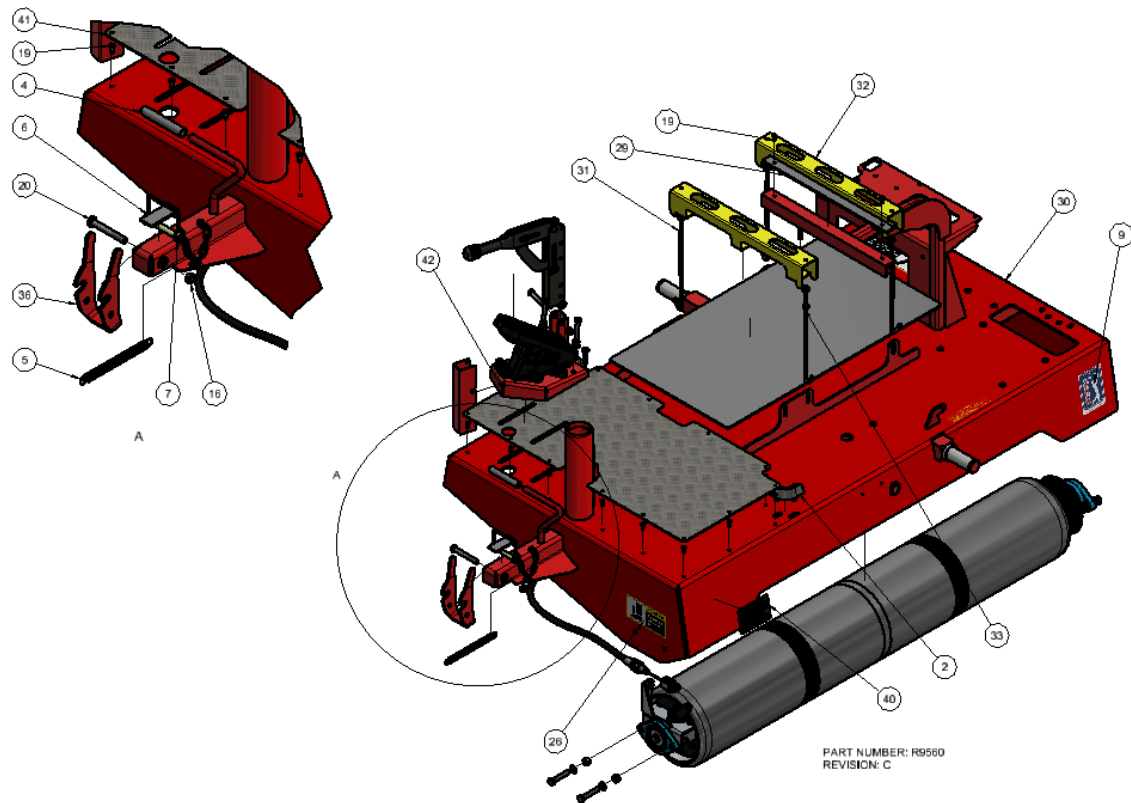

Assembly, Body

R9560 PARTS LIST							
ITEM	QTY	PART NUMBER	DESCRIPTION	ITEM	QTY	PART NUMBER	DESCRIPTION
1	4	E7076	CLIP, P, 10 mm	23	1	R8847	DECAL, CLOSE COVER INSTRUCTIONS
2	2	E7128	MOULDING, CORNER REST	24	1	R8963	MAT, RUBBER, BATTERY
3	1	E7286	ASSEMBLY, FLEXI BELT DRIVE ROLLER	25	1	R9086	DECAL, PINCH POINT - FINGERS
4	1	R5014	GRIP, HAND - 12 ID x 90 LG	26	2	R9087	DECAL, PINCH POINT - FEET
5	1	R5049	SPRING, EXTENSION, ZP - $\emptyset 1/2$ "x18g.x5" LG	27	1	R9101	WELDMENT, BRACKET, FOOT PEDAL
6	1	R5159	REST, RUBBER, TRAILER - 3 mm THK.	28	2	R9210	4-5 RIVET, ALUMINIUM, BLK
7	1	R6017	ASSEMBLY, DRAWBAR SAFETY PIN & CHAIN	29	1	R9527	PACKER, T-BAR SUPPORT
8	1	R6023	PLATE, LABEL, PARK BRAKE	30	1	R9561	WELDMENT, BODY
9	1	R6059	DECAL, PGA TOUR	31	4	R9872	1/4" UNC X 10" HOLD-DOWN BOLT, ZP
10	1	R7024	HANDBRAKE LEVER	32	2	R9874	BRACKET, BATTERY CLAMP
11	4	R8034	M8 SPRING WASHER, ZP	33	1	R9875	1/4" UNC NYLOC NUT, ZP
12	4	R8043	M8 NUT, ZP	34	2	R9983	TUBE, SPACER
13	2	R8046	5/16" X 3/4" FLAT WASHER, ZP	35	2	R9987	M8 X 35, CSK HEAD SCREW, ZP
14	1	R8053	1/4" UNF NYLOC NUT, ZP	36	1	RS2117	CATCH, WIDE, FOLDED, TRAILER DRAWBAR
15	2	R8054	5/16" UNF NYLOC NUT, ZP	37	1	RS2126	COVER, SAFETY, S/S, HANDBRAKE LEVER
16	1	R8056	3/8" UNF NYLOC NUT, (TYPE T), ZP	38	1	RS2183	MUD FLAP
17	2	R8081	10-24 X 16 TEK SCREW, ZP	39	1	RS2184	STRAP, MUDFLAP, SCREW ON
18	2	R8095	5/16" UNF X 2" BOLT, ZP	40	1	RS2210	DECAL, SERIAL NUMBER, RE50
19	18	R8134	6-6 RIVET, ALUMINIUM	41	1	RS2212	FOOT PAD
20	1	R8190	3/8" UNF X 2-3/4" BOLT, ZP	42	1	RS2236	ASSEMBLY, FOOT PEDAL, CURTIS
21	1	R8452	DECAL, WARNING - DO NOT OPERATE WITHOUT STRUT	43	1	T7034	CABLE ASSY - PARK DRUM BRAKE TYPE
22	2	R8676	BUFFER, INTERNAL THREADED				

Assembly, Body

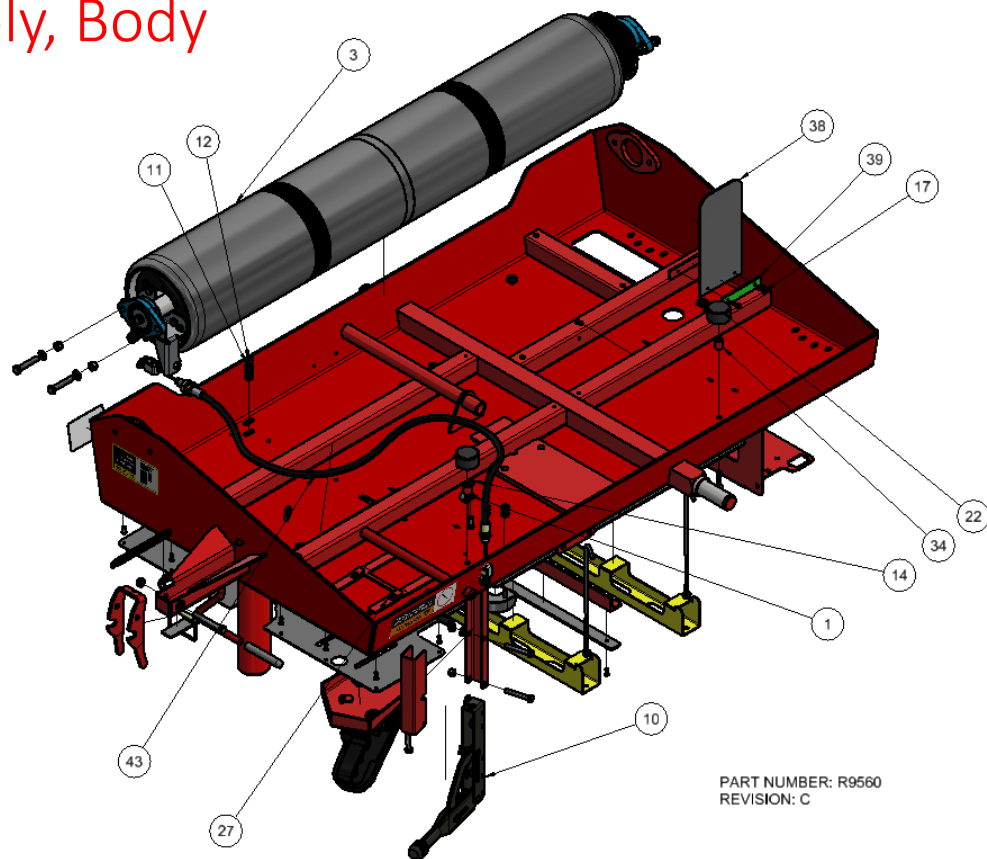

PART NUMBER: R9560
REVISION: C

Assembly, Body

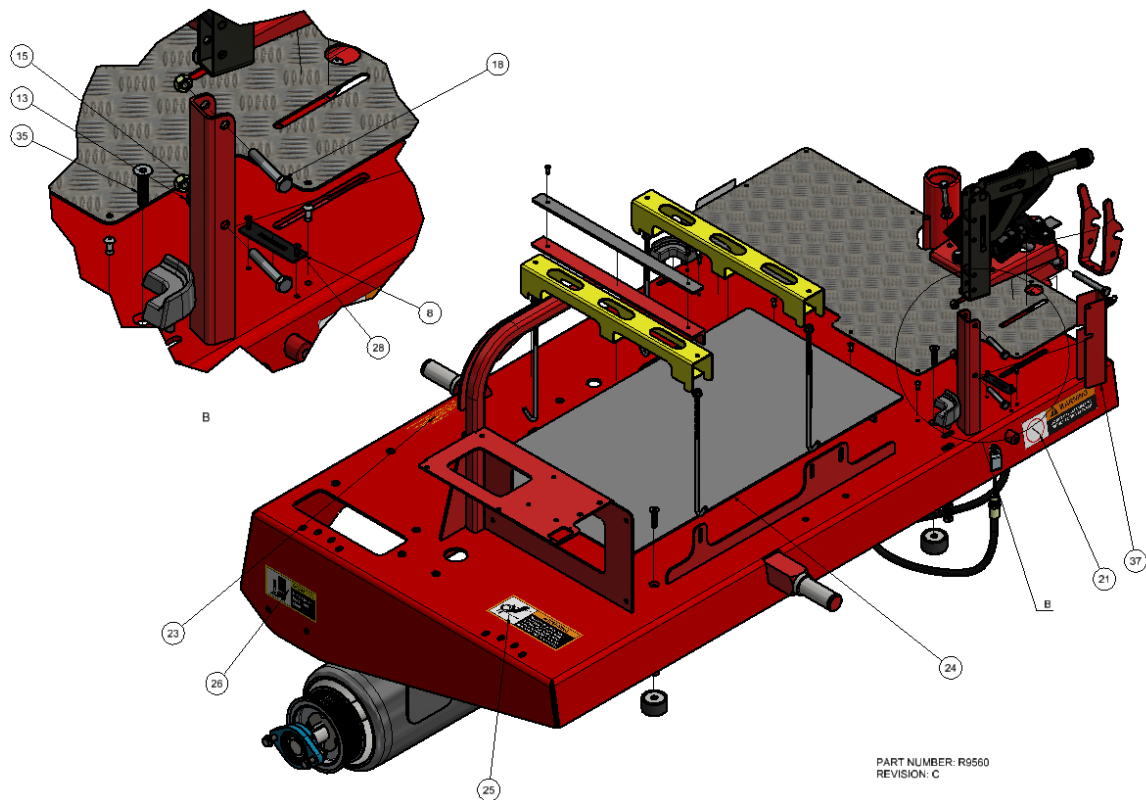

PART NUMBER: R9500
REVISION: C

Assembly, Drive Unit

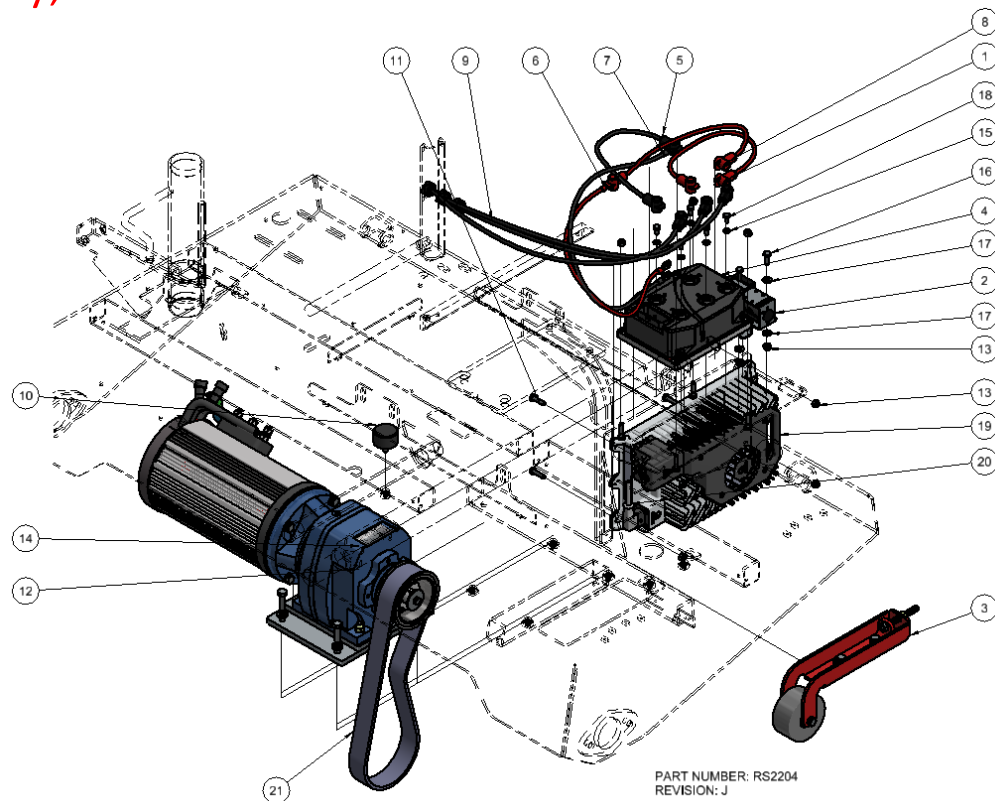

PART NUMBER: RS2204
REVISION: J

Assembly, Drive Unit

RS2204 PARTS LIST			
ITEM	QTY	PART NUMBER	DESCRIPTION
1	1	E7090	POWER CABLE B+ CONTROLLER TO SOLENOID RIGHT
2	1	E7200	CONTACTOR, SOLENOID, 48V DC
3	1	E7254	ASSEMBLY, BELT TENSIONER
4	1	E7297	CONTROLLER, AC INDUCTION MOTOR
5	1	E7310	POWER CABLE B- CONTROLLER TO BATT NEG
6	1	E7311	POWER CABLE CHARGER POS POLE TO BATT POS
7	1	E7312	POWER CABLE CHARGER NEG POLE TO BATT NEG
8	1	E7329	POWER CABLE, SOLENOID LEFT PIN TO BATT POS
9	3	E7331	POWER CABLE CONTROLLER TO MOTOR AC UNIT
10	1	R6013	BUFFER STOP, UNDER BODY
11	8	R8033	1/4" UNF X 1" BOLT, ZP
12	4	R8052	3/8" SPRING WASHER, ZP
13	10	R8053	1/4" UNF NYLOC NUT, ZP
14	4	R8069	3/8" UNF X 1-1/4" SET SCREW, ZP
15	5	R8085	M6 SPRING WASHER, ZP
16	2	R8137	1/4" UNF X 3/4" SET SCREW, ZP
17	4	R8140	1/4" X 5/8" X 0.065" FLAT WASHER, ZP
18	5	R8327	M6 X 12 BOLT, ZP
19	1	R8705	BATTERY CHARGER, 48VDC, Delta-Q IC1200
20	1	R8845	COMPUTER POWER CABLE - RIGHT ANGLE
21	1	RS2205	ASSEMBLY, ELECTRIC BELT DRIVE



Assembly, Electric Belt Drive

RS2205 PARTS LIST			
ITEM	QTY	PART NUMBER	DESCRIPTION
1	1	E7032	BUSH, TAPER LOCK - 1610-1
2	1	E7036	KEY, ELECTRIC MOTOR
3	1	E7039	REDUCTION GEARBOX
4	1	E7053	SQ KEY, 1/4" X 1/4" X 1.575"
5	1	E7072	SPROCKET, BELT DRIVE, 8MX-38S-36
6	1	E7074	DRIVE BELT, 8MGT-960-36
7	1	E7196	ELECTRIC MOTOR, 48V
8	1	E7201	WELDMENT, GEARBOX MOUNT PLATE, BELT DRIVE
9	1	R8050	1/4" SPRING WASHER, ZP
10	4	R8055	3/8" UNF NYLOC NUT, ZP
11	4	R8123	3/8" UNF X 2" FLAT HEAD SOCKET SCREW, ZP
12	4	R8127	M10 SPRING WASHER, ZP
13	1	R8137	1/4" UNF X 3/4" SET SCREW, ZP
14	4	R8138	3/8" UNC X 1-1/4" BOLT, ZP
15	1	R8255	1/4" X 1-1/2" FLAT WASHER, ZP
16	2	R8437	3/8" UNC X 5/8" GRUB SCREW

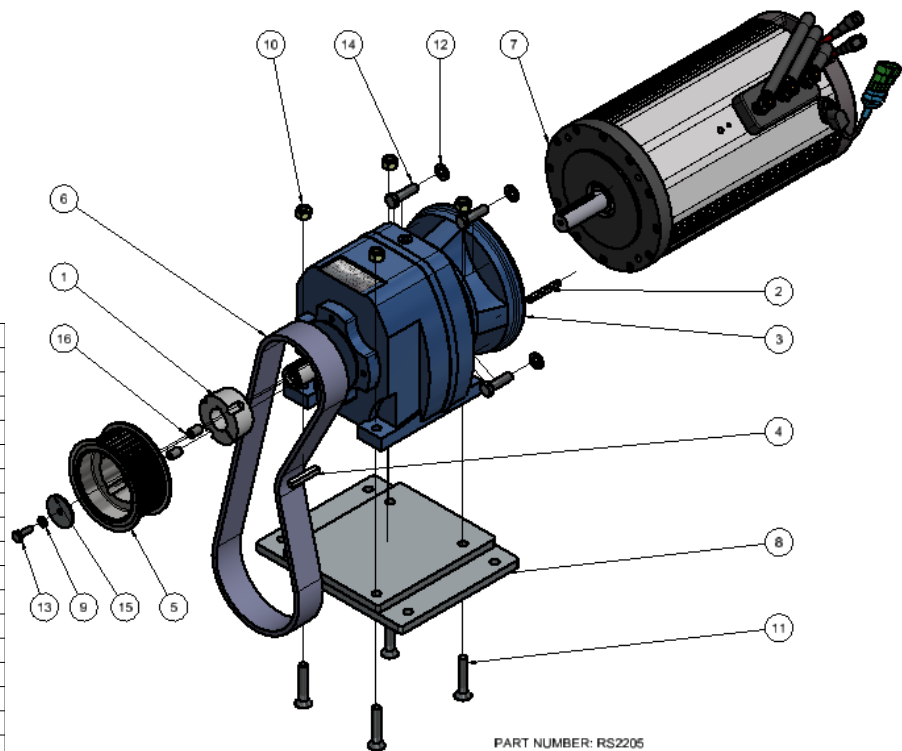

PART NUMBER: RS2205
REVISION: C

Pulley Alignment

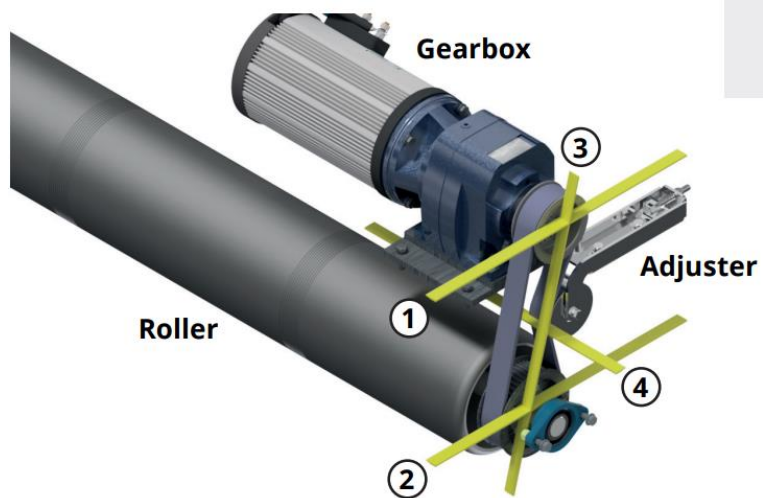

Straight Edges

- ① & ② Parallel
- ③ Should be within $1/2^\circ$
- ④ Idler pulley should be parallel to drive roller/axle.

Drive Belt Tensioning Instructions

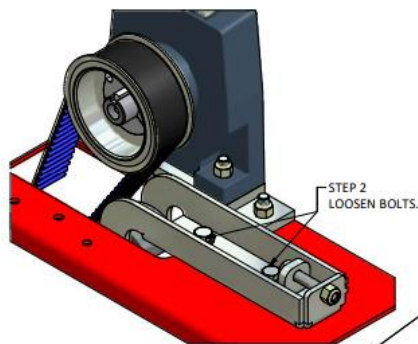

STEP 2
LOOSEN BOLTS.

TENSION NEW BELTS TO:
6mm / 1/4" DEFLECTION WITH
12-14kg / 26-30lb OF FORCE.

USED BELTS:
MEASURE & RECORD THE
BELT TENSION BEFORE REMOVAL.
REFIT THE BELT TO THE
SAME TENSION AS RECORDED.

FITTING THE BELT

IS SIMPLY THE REVERSE OF
THE STEPS TO REMOVE THE BELT.

NOTE:

TAKE CARE NOT TO CRUSH OR CUT THE BELT.

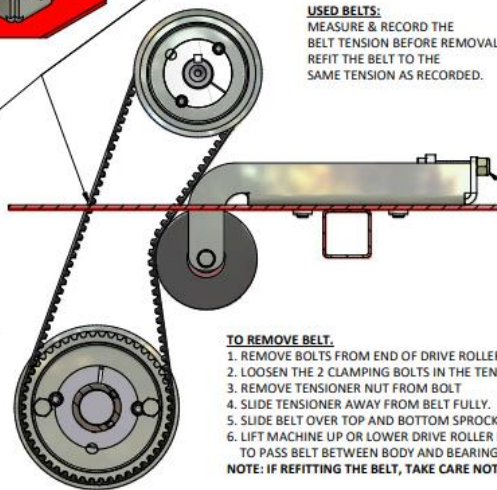

TO REMOVE BELT.

1. REMOVE BOLTS FROM END OF DRIVE ROLLER BEARING.
2. LOOSEN THE 2 CLAMPING BOLTS IN THE TENSIONER.
3. REMOVE TENSIONER NUT FROM BOLT
4. SLIDE TENSIONER AWAY FROM BELT FULLY.
5. SLIDE BELT OVER TOP AND BOTTOM SPROCKETS AT THE SAME TIME.
6. LIFT MACHINE UP OR LOWER DRIVE ROLLER ENOUGH TO PASS BELT BETWEEN BODY AND BEARING HOUSING.

NOTE: IF REFITTING THE BELT, TAKE CARE NOT TO CRUSH OR CUT THE BELT.



WHEN FITTING BELT,
ADJUST POSITION OF
SPROCKET & BUSH TO
ENSURE THE BELT WILL
RUN IN THE CENTRE OF THE
TENSIONER IDLER WHEEL.

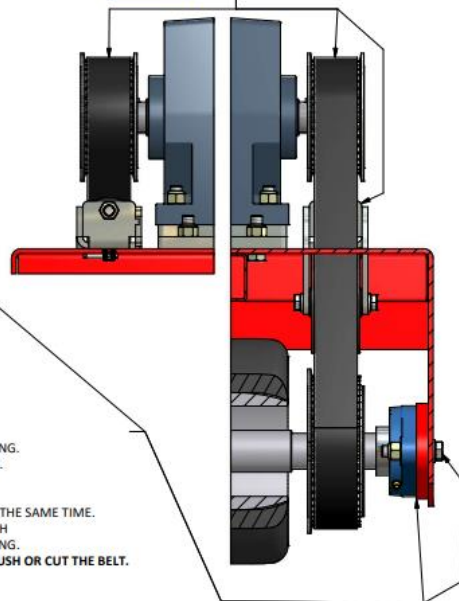

Assembly, Flex Tube Drive Roller

E7034 PARTS LIST			
ITEM	QTY	PART NUMBER	DESCRIPTION
1	1	E7099	COUPLING, FLEX TUBE
2	2	E7102	OUTER CLAMP RING
3	2	E7103	INNER CLAMP RING
4	2	E7116	DRIVE CENTRE, INSERT, POLYURETHANE
5	1	E7171	WELDMENT, FLEXI DRIVE ROLLER SHAFT
6	20	R8051	5/16" SPRING WASHER, ZP
7	20	R8064	5/16" UNF X 1" SET SCREW, ZP

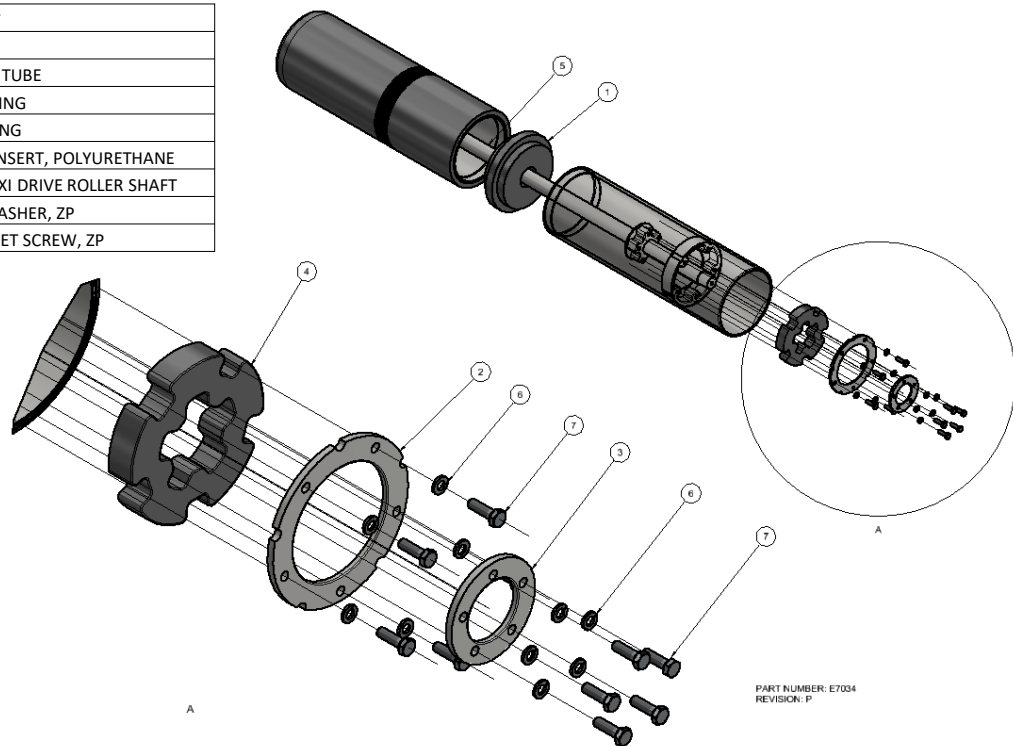

PART NUMBER: E7034
REVISION: P

Assembly, Flex Belt Drive Roller

E7286 PARTS LIST			
ITEM	QTY	PART NUMBER	DESCRIPTION
1	1	E7010	M10 X 43 X 3 FLAT WASHER, ZP
2	1	E7034	ASSEMBLY, FLEX TUBE DRIVE ROLLER
3	1	E7073	SPROCKET - GATES 8XM-50S-36
4	2	R5265	BEARING UNIT ASSY - SBLF206
5	1	R7037	DRUM BRAKE ASSY - FLEX TUBE DRIVE ROLLER
6	4	R8048	3/8" X 3/4" FLAT WASHER, ZP
7	1	R8052	3/8" SPRING WASHER, ZP
8	4	R8055	3/8" UNF NYLOC NUT, ZP
9	1	R8067	3/8" UNF X 1" BOLT, ZP
10	2	R8096	3/8" UNF X 1-3/4" SET SCREW, ZP
11	2	R8097	3/8" UNF X 2" BOLT, ZP
12	2	R8125	7/16" UNC X 0.83 GRUB SCREW, BLK
13	1	R9112	KEY, STEEL, 8x8x47
14	1	R9228	TAPER LOCK BUSHING, 2012-30

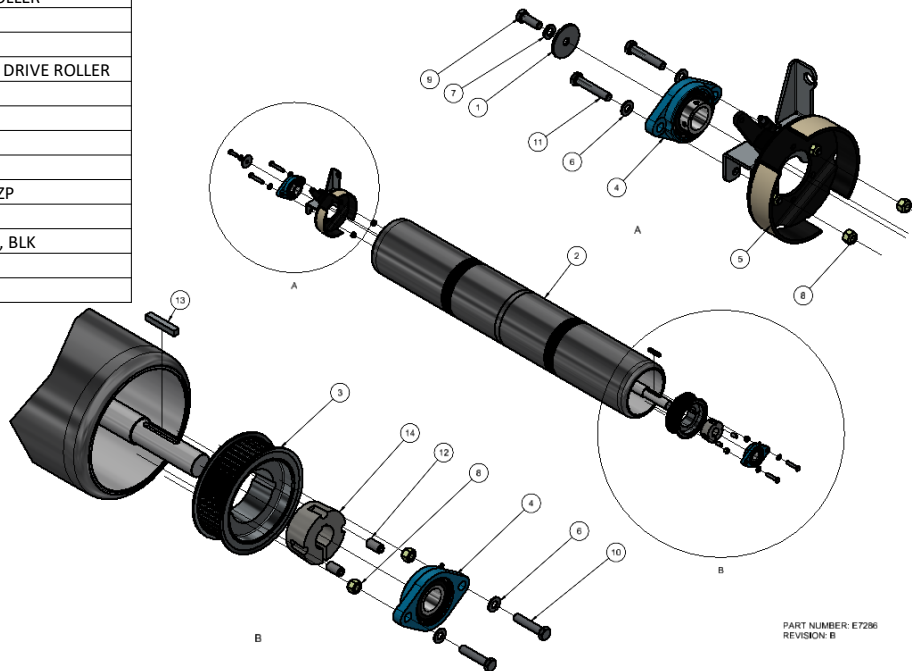

PART NUMBER: E7286
REVISION: B

Assembly, Steering – Overlapping Heads

RS2500 PARTS LIST			
ITEM	QTY	PART NUMBER	DESCRIPTION
1	2	R5266	BEARING, UCP204, PILLOW BLOCK ASSY
2	4	R8048	3/8" X 3/4" FLAT WASHER, ZP
3	12	R8055	3/8" UNF NYLOC NUT, ZP
4	8	R8069	3/8" UNF X 1-1/4" SET SCREW, ZP
5	2	R8096	3/8" UNF X 1-3/4" SET SCREW, ZP
6	1	R8101	1/2" UNF NYLOC NUT, ZP
7	2	R8123	3/8" UNF X 2" FLAT HEAD SOCKET SCREW, ZP
8	1	RS2039	ASSEMBLY, STEERING CONNECTING ROD
9	1	RS2047	WELDMENT, PIVOT BEAM
10	1	RS2052	ASSEMBLY, SMOOTHING HEAD, FRONT
11	1	RS2054	ASSEMBLY, SMOOTHING HEAD, REAR
12	2	RS2059	CAP, SHS END, PLASTIC, BLACK - 1.5" SQ.
13	1	RS2060	ASSEMBLY, STEERING BRACE
14	1	RS2182	SPACER, STEERING ARM

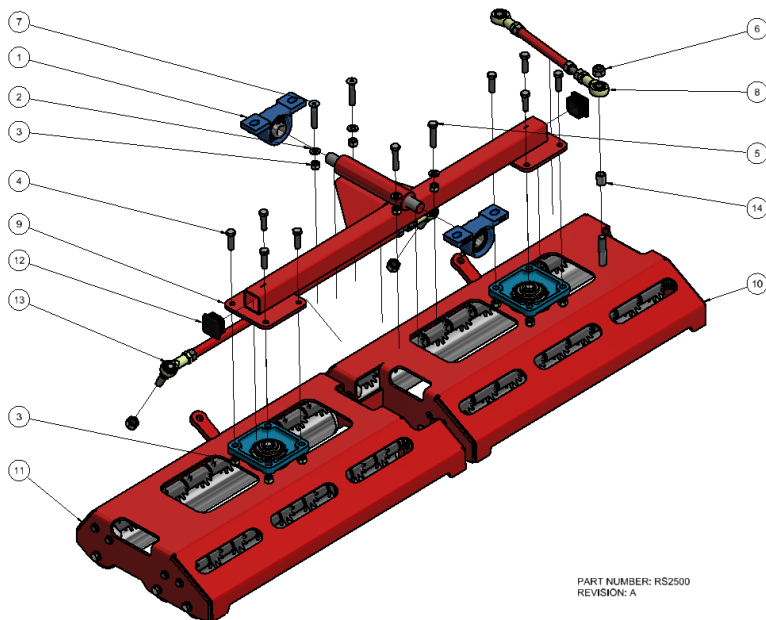

PART NUMBER: RS2500
REVISION: A

Assembly, Front Smoothing Head

RS2052 PARTS LIST			
ITEM	QTY	PART NUMBER	DESCRIPTION
1	1	E7216	BEARING UNIT ASSY UCF206
2	4	R8052	3/8" SPRING WASHER, ZP
3	1	R8066	3/8" UNF X 3/4" BOLT, ZP
4	3	R8067	3/8" UNF X 1" BOLT, ZP
5	4	R8137	1/4" UNF X 3/4" SET SCREW, ZP
6	4	R8140	1/4" X 5/8" X 0.065" FLAT WASHER, ZP
7	3	R8158	3/8" UNF X 1" FLAT HEAD SOCKET SCREW, ZP
8	2	R8217	SMOOTHING ROLLER COMPLETE ASSY
9	1	R8225	WASHER, MOULDED, RUBBER, DAMPNER
10	1	R8468	ASSEMBLY, NODULE SWEEPER
11	8	R8836	1/4" UNF NYLOC NUT, (TYPE T), ZP
12	4	R9421	ASSEMBLY, BEARING HOUSING, NODULE
13	4	R9526	1/4" UNF X 3/4" FLAT HEAD SOCKET SCREW, ZP
14	1	RS2050	SMOOTHING ROLLER, LONG, COMPLETE ASSY
15	1	RS2051	WELDMENT, STEERING HEAD, FRONT
16	1	RS2055	ASSEMBLY, NODULE SWEEPER

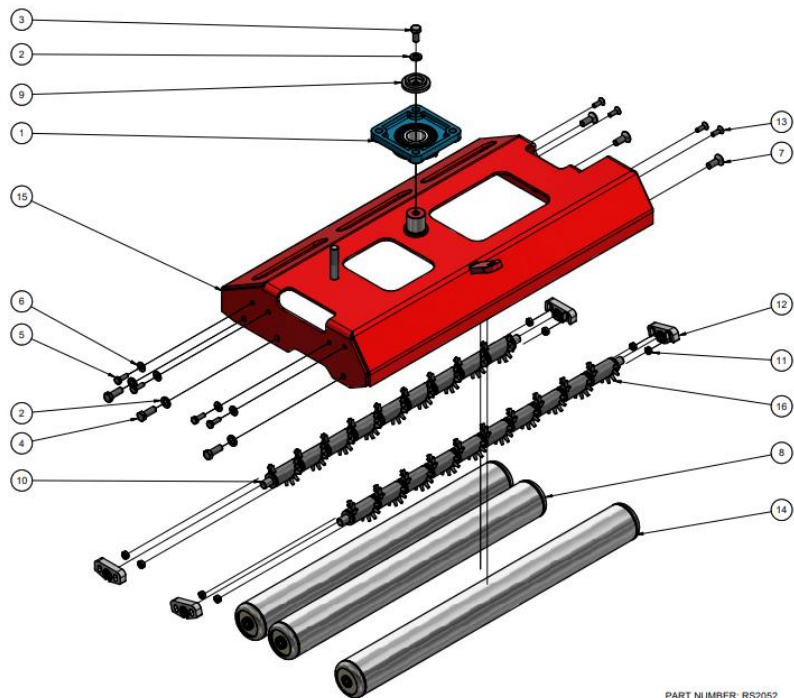

PART NUMBER: RS2052
REVISION: H

Assembly, Rear Smoothing Head

RS2054 PARTS LIST			
ITEM	QTY	PART NUMBER	DESCRIPTION
1	1	E7216	BEARING UNIT ASSY UCF206
2	4	R8052	3/8" SPRING WASHER, ZP
3	1	R8066	3/8" UNF X 3/4" BOLT, ZP
4	3	R8067	3/8" UNF X 1" BOLT, ZP
5	4	R8137	1/4" UNF X 3/4" SET SCREW, ZP
6	4	R8140	1/4" X 5/8" X 0.065" FLAT WASHER, ZP
7	3	R8158	3/8" UNF X 1" FLAT HEAD SOCKET SCREW, ZP
8	2	R8217	SMOOTHING ROLLER COMPLETE ASSY
9	1	R8225	WASHER, MOULDED, RUBBER, DAMPNER
10	2	R8468	ASSEMBLY, NODULE SWEEPER
11	8	R8836	1/4" UNF NYLOC NUT, (TYPE T), ZP
12	4	R9421	ASSEMBLY, BEARING HOUSING, NODULE
13	4	R9526	1/4" UNF X 3/4" FLAT HEAD SOCKET SCREW, ZP
14	1	RS2050	SMOOTHING ROLLER, LONG, COMPLETE ASSY
15	1	RS2053	WELDMENT, STEERING HEAD, REAR

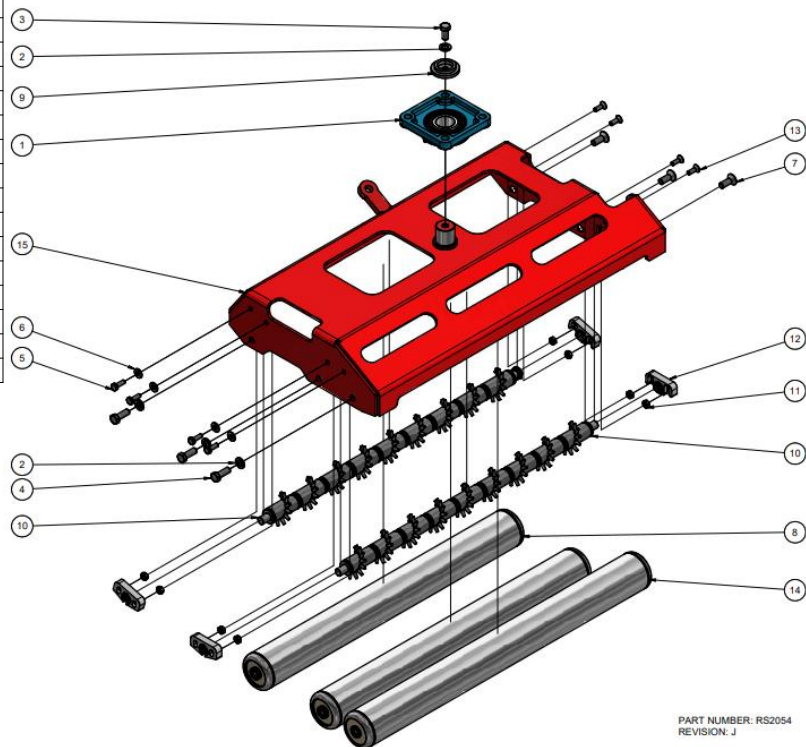

PART NUMBER: RS2054
REVISION: J

Assembly, Nodule Sweeper, (Short)

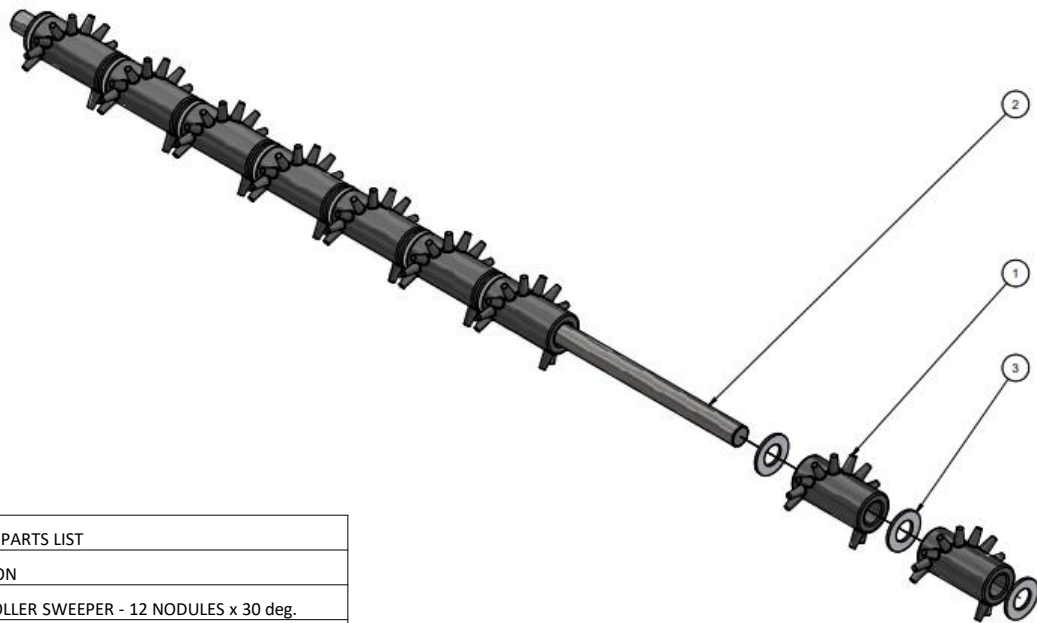

R8468 PARTS LIST			
ITEM	QTY	PART NUMBER	DESCRIPTION
1	9	R8461	RUBBER ROLLER SWEEPER - 12 NODULES x 30 deg.
2	1	R8509	SHAFT, RUBBER ROLLER SWEEPER
3	10	R9536	0.525" X 1" X 0.062" FLAT WASHER, NYLON

PART NUMBER: R8468
REVISION: F

Assembly, Nodule Sweeper, (Long)

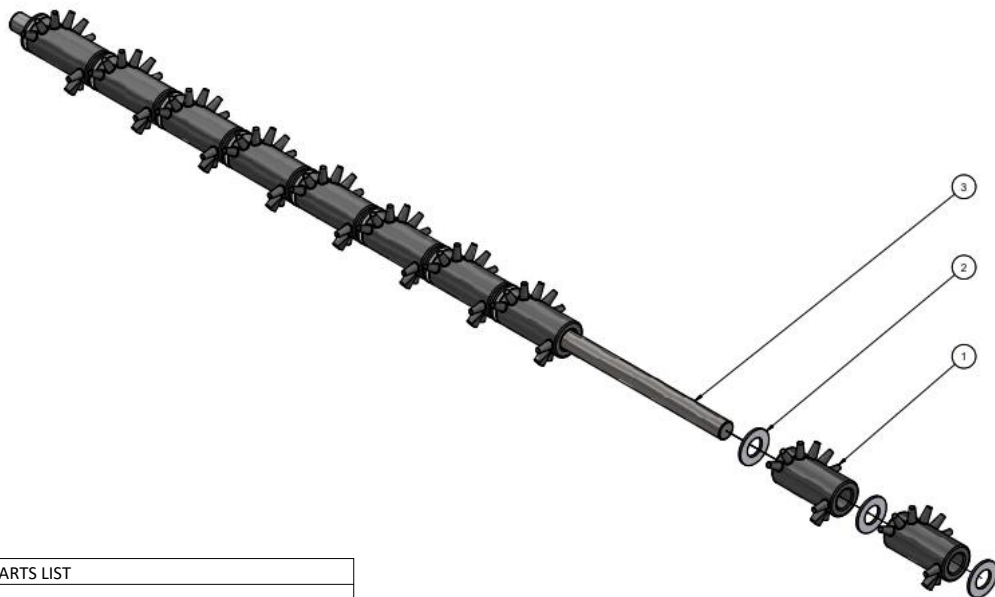

PART NUMBER: RS2055
REVISION: G

RS2055 PARTS LIST			
ITEM	QTY	PART NUMBER	DESCRIPTION
1	10	R8461	RUBBER ROLLER SWEEPER - 12 NODULES x 30 deg.
2	11	R9536	0.525" X 1" X 0.062" FLAT WASHER, NYLON
3	1	RS2056	SHAFT, LONG, RUBBER ROLLER SWEEPER

Connecting Rods

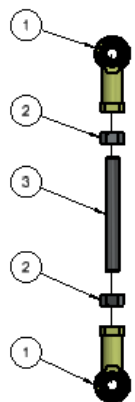

RS2285

RS2285 PARTS LIST			
ITEM	QTY	PART NUMBER	DESCRIPTION
1	2	R5118	3/8" UNF ROD END, FEMALE
2	2	R8091	3/8" UNF NUT, ZP
3	1	RS2286	THREADED ROD, STABILISING

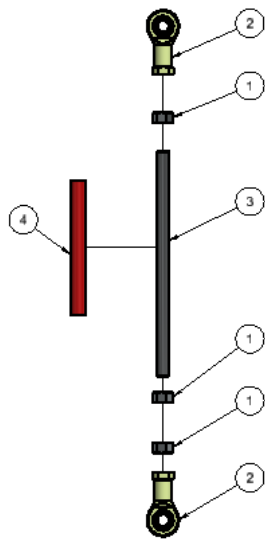

RS2039

RS2039 PARTS LIST			
ITEM	QTY	PART NUMBER	DESCRIPTION
1	3	R8284	1/2" UNF NUT, ZP
2	2	R8285	1/2" UNF ROD END, FEMALE, ZP
3	1	RS2088	THREADED ROD, STEERING
4	1	RS2089	TUBE, STEERING TIE ROD

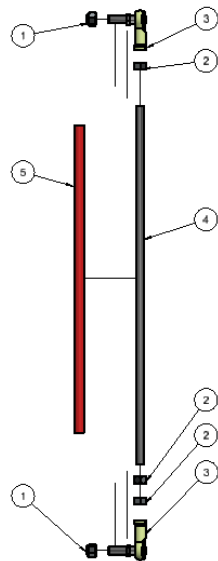

RS2326

RS2326 PARTS LIST			
ITEM	QTY	PART NUMBER	DESCRIPTION
1	2	R8101	1/2" UNF NYLOC NUT, ZP
2	3	R8284	1/2" UNF NUT, ZP
3	2	R8287	1/2" UNF ROD END, MALE
4	1	RS2324	ROD, THREADED - 1/2" UNF
5	1	RS2325	TUBE, TIE ROD, STEER SMOOTHING HEADS

Assembly, Electric Joystick

RS2208 PARTS LIST			
ITEM	QTY	PART NUMBER	DESCRIPTION
1	1	E7159	ASSEMBLY, JOYSTICK WIRING HARNESS
2	1	E7218	GUARD, SWITCH, TOGGLE, JOYSTICK
3	1	R5049	SPRING, EXTENSION, ZP - $\varnothing 1/2$ "x18g.x5" LG
4	1	R5156	1/8" X 5/8" WOODRUFF KEY
5	1	R6009	JOYSTICK SHAFT, WELDED, ASSY
6	2	R8018	BALL BEARING S6304-2RS, SS
7	2	R8055	3/8" UNF NYLOC NUT, ZP
8	1	R8060	1/2" UNC NYLOC NUT, ZP
9	2	R8070	3/8" UNF X 1-1/2" SET SCREW, ZP
10	1	R8101	1/2" UNF NYLOC NUT, ZP
11	1	R8295	1/4" UNF X 1/4" GRUB SCREW ,BLK
12	1	R9569	GRIP, ELECTRICAL JOYSTICK
13	1	R9790	ASSEMBLY, SWITCH, DIRECTIONAL CONTROL
14	1	RS2019	ARM, STEERING, WELDED, ASSY - 1/2" UNF
15	1	RS2207	WELDMENT, JOYSTICK

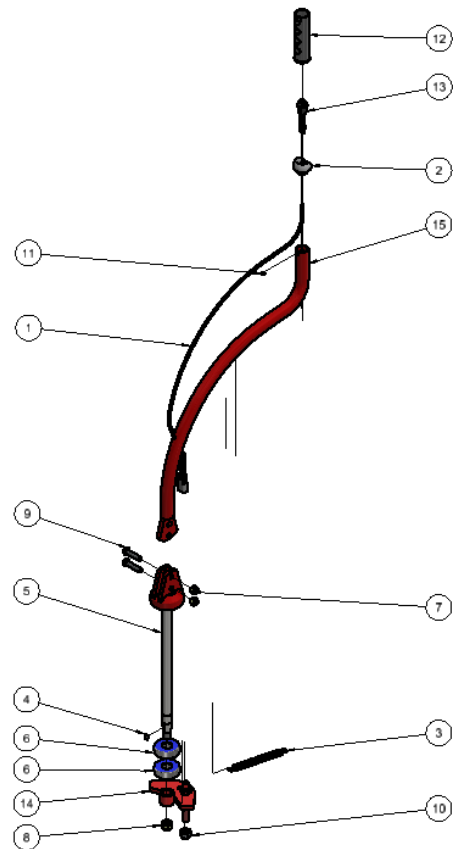

PART NUMBER: RS2208
REVISION: H

Assembly, Trailer Frame

RS2043 PARTS LIST			
ITEM	QTY	PART NUMBER	DESCRIPTION
1	2	E7007	BUSH, FLANGED
2	1	R5202	GAS STRUT, 620
3	1	R8036	M2.5 x 20 SPLIT PIN, ZP
4	1	R8038	M10 X 40 BOLT, ZP
5	4	R8048	3/8" X 3/4" FLAT WASHER, ZP
6	2	R8055	3/8" UNF NYLOC NUT, ZP
7	2	R8082	CIRCLIP, EXT, BLK, 30mm
8	1	R8088	M10 NUT, ZP
9	1	R8174	M10 X 20 FLAT WASHER, ZP
10	2	R8190	3/8" UNF X 2-3/4" BOLT, ZP
11	1	R8366	WELDMENT, TRAILER ARM, LH
12	1	R8367	WELDMENT, TRAILER ARM, RH
13	1	R8858	DECAL, DRAWBAR USE WARNING
14	2	R9037	WHEEL HUB COMPLETE PARALLEL AXLE
15	2	R9074	WHEEL, 4 STUD, 18" TYRE
16	1	RS2104	DRAWBAR TOWBALL COUPLING ASSY
17	2	RS2424	BUSH, FLANGED, CHAMFERED

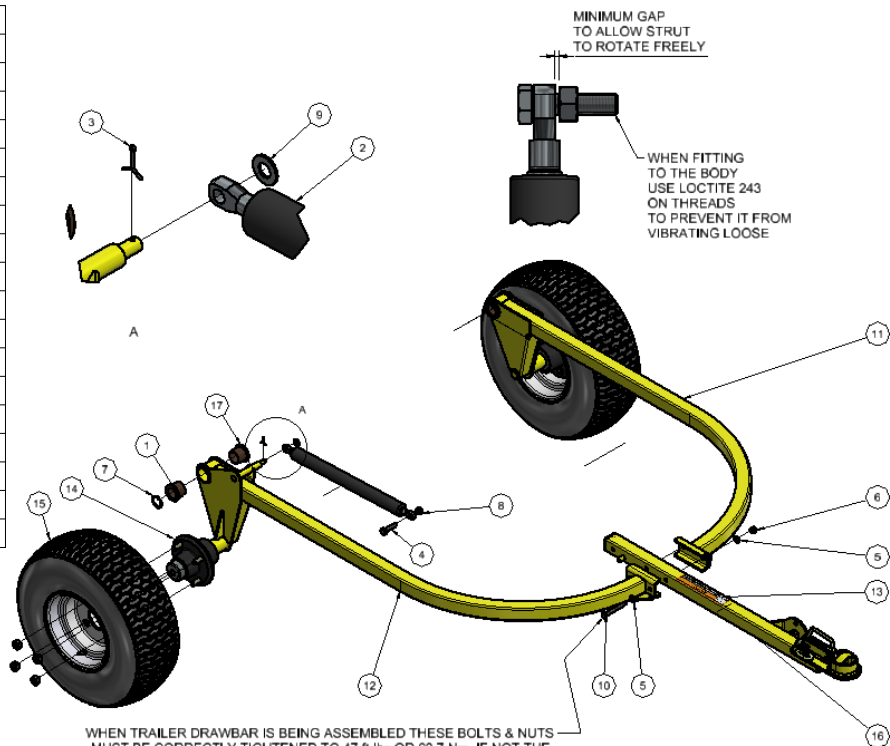

WHEN TRAILER DRAWBAR IS BEING ASSEMBLED THESE BOLTS & NUTS MUST BE CORRECTLY TIGHTENED TO 47 ft-lbs OR 63.7 Nm. IF NOT THE DRAWBAR CAN BECOME LOOSE AND THE HOLES WILL WEAR MAKING IT DANGEROUS WHEN TOWING OR RAISING / LOWERING THE TRAILER.

PART NUMBER: RS2043
REVISION: F

Assembly, Jockey Post

RS2190 PARTS LIST			
ITEM	QTY	PART NUMBER	DESCRIPTION
1	1	RS2191	WELDMENT LEG, JOCKEY POST
2	1	R5025B	CAP, END, BLACK, PLASTIC - 35x35
3	1	E7222	PULL PIN ASSY, FOR JOCKEY WHEEL, USA BUILD
4	1	R8352	NUT, HEX, JAMB, ZP - 1/2" UNF
5	1	R8099	1/2" UNF X 2-3/4" BOLT, ZP
6	1	R8503	1/2" FLAT WASHER, ZP

LOCK NUT TO BE TIGHTENED
AFTER THE JOCKEY WHEEL LEG
IS IN THE CORRECT
OPERATIONAL LOCATION

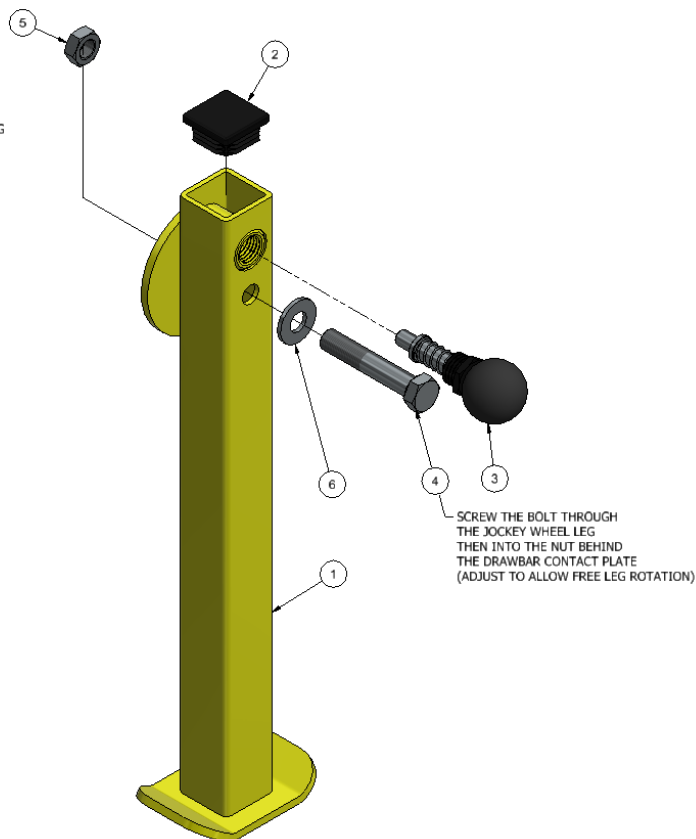

Assembly, Trailer Hub

R9037 PARTS LIST			
ITEM	QTY	PART NUMBER	DESCRIPTION
1	1	R9029	SEAL, INNER HUB - CR 12610
2	2	R9030	BEARING, TAPERED ROLLER - L44643
3	1	R9032	WASHER, STUB AXLE (19x38)
4	1	R9033	NUT, CASTLE, 3/4"-16 UNF
5	1	R9034	PIN, COTTER, (SPLIT) - M4 x 40
6	1	R9035	CAP, HUB BEARING
7	4	R9036	NUT, WHEEL, 1/2 "UNF (USA)
8	1	R9038	HUB, TRAILER, PARALLEL AXLE

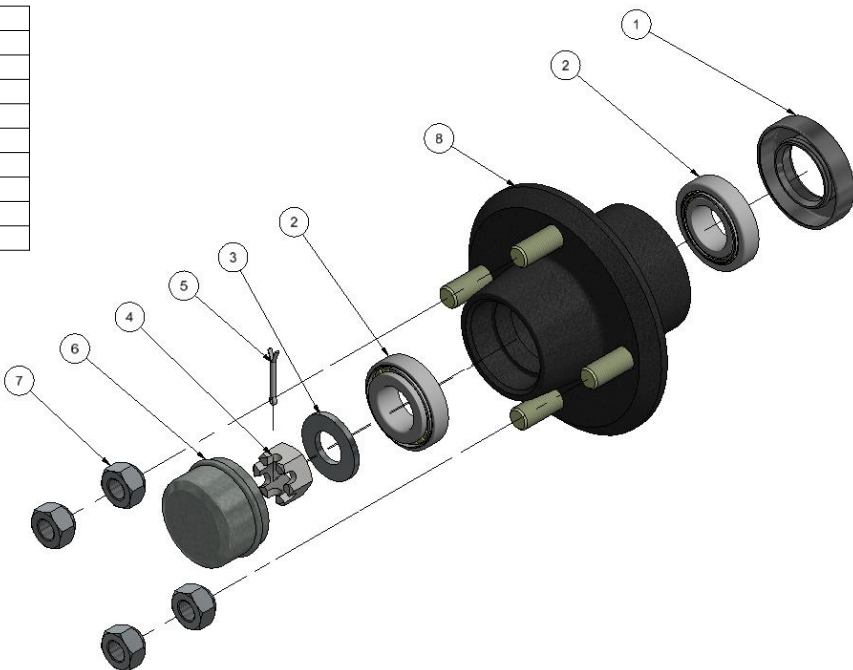

NOTE: R9037 HUB IS PURCHASED AS A COMPLETE ASSEMBLY ITEM

Assembly, Seat

FITTING INSTRUCTIONS

NOTE: WHEN FITTING THIS SEAT TO THE BASE PLATE
THE RECOMMENDED DYNAMIC TORQUE FOR THE SEAT
BOLTS IS 80±15 IN.LBS (DO NOT EXCEED 180 IN.LBS)
ARMREST BRACKET BOLTS IS 70±10 IN.LBS

R8365 PARTS LIST

ITEM	QTY	PART NUMBER	DESCRIPTION
1	1	R8362	SEAT ALL PVC PAN ONLY MSC
2	1	R8363	ARM REST, RH, ASSY, MILSCO
3	1	R8364	ARM REST, LH, ASSY, MILSCO

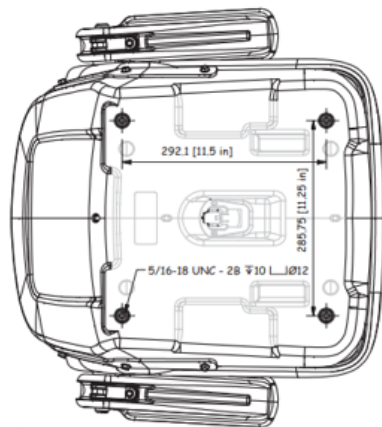

BOTTOM VIEW

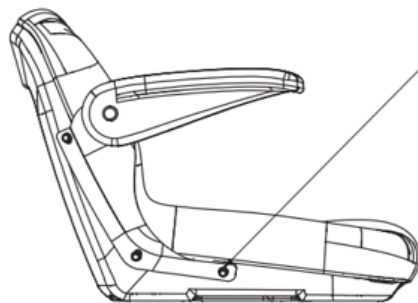

SIDE VIEW

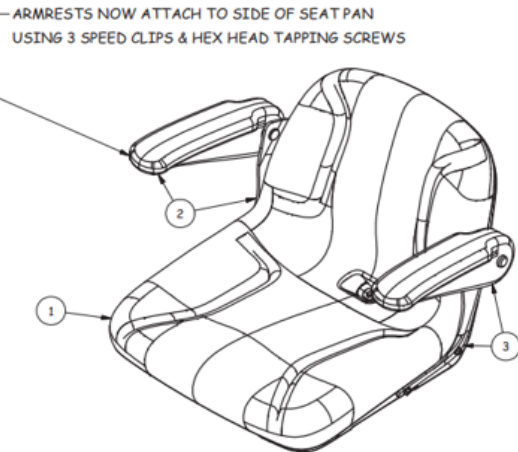

Options: Kit

PARTS LIST			
ITEM	QTY	PART NUMBER	DESCRIPTION
1	1	RS2010	ASSEMBLY, BOX 4 - BRUSH KIT
2	1	RS2040	ASSEMBLY, BOX 2 - SPIKER KIT
3	1	RS2067	ASSEMBLY, BOX 3 - SLICER KIT
4	1	RS2070	ASSEMBLY, BOX 1 - H-FRAME & LEVER

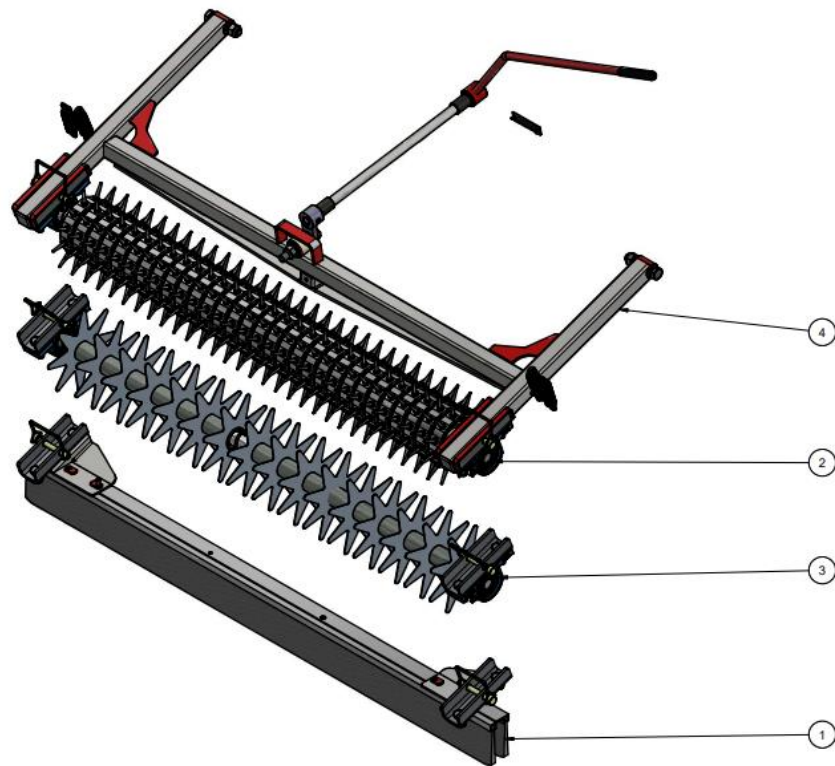

For options kit fitting instructions, click [here](#).

Harness Loom

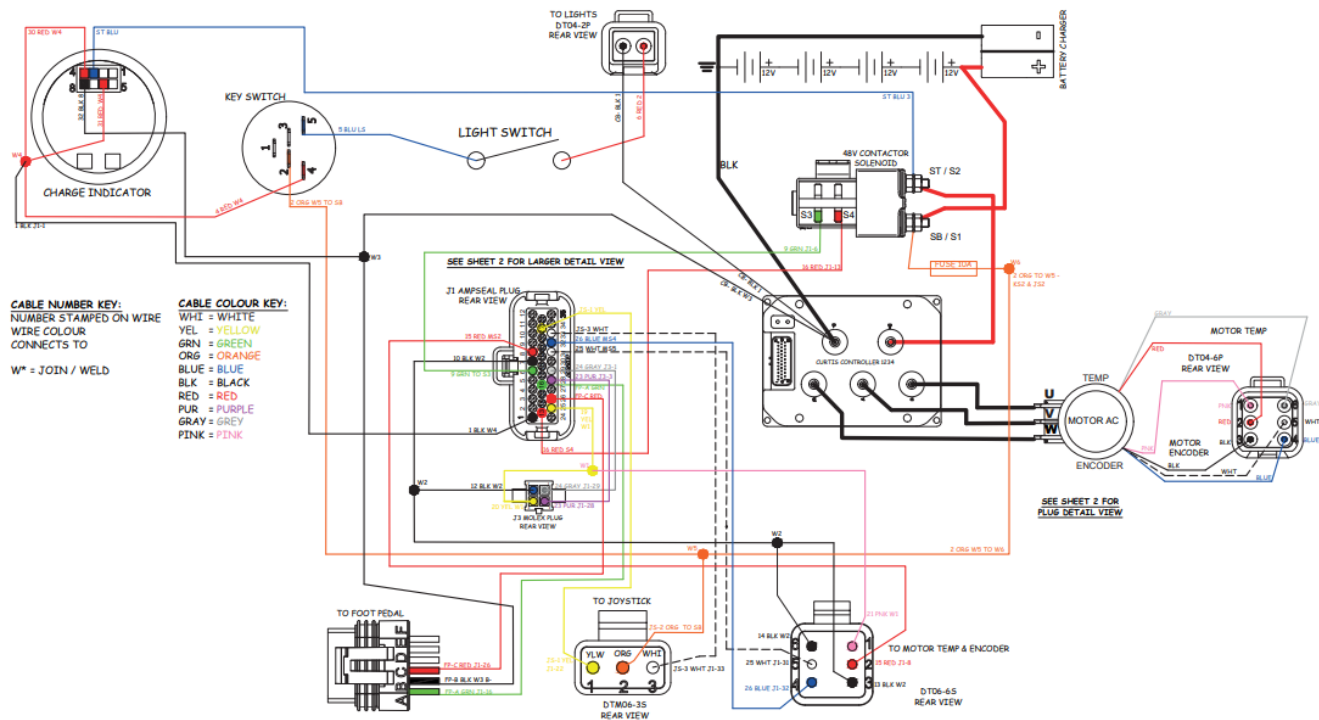

Harness Loom

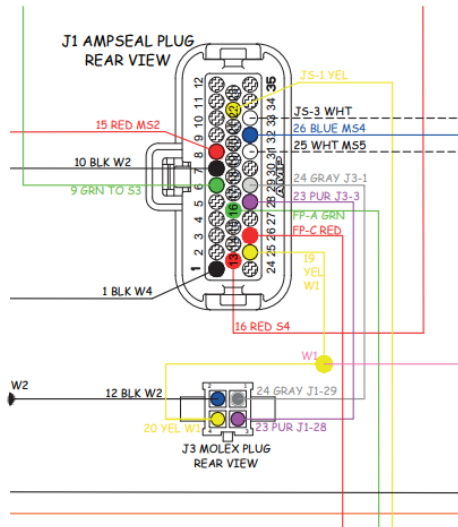

CABLE NUMBER KEY:
NUMBER STAMPED ON WIRE
WIRE COLOUR
CONNECTS TO

W* = JOIN / WELD

CABLE COLOUR KEY:
WHI = WHITE
YEL = YELLOW
GRN = GREEN
ORG = ORANGE
BLUE = BLUE
BLK = BLACK
RED = RED
PUR = PURPLE
GRAY = GREY
PINK = PINK

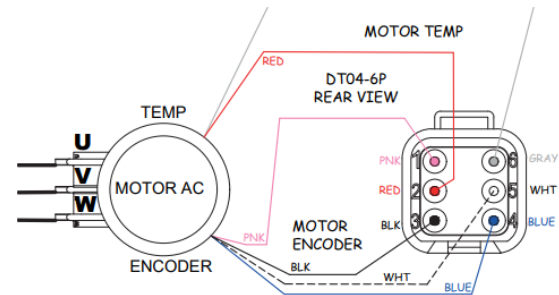

Motor Controller Fault Codes

The process allows you interpret the fault codes displayed on the AC motor controller unit fitted to your golf greens roller.

This information can be obtained by observing the fault codes issued by the Status LEDs.



The pair of LEDs built into the controller (one red, one yellow) produce flash codes displaying all the currently set faults in a repeating cycle.

Each code consists of two digits.

1. The red LED flashes once to indicate that the first digit of the code will follow.
2. The yellow LED then flashes the appropriate number of times for the first digit.
3. The red LED flashes twice to indicate that the second digit of the code will follow.
4. The yellow LED flashes the appropriate number of times for the second digit.

The numerical codes used by the yellow LED are listed in the following troubleshooting chart, which also lists possible fault causes and describes the conditions that set and clear each fault.

Example: Battery Under Voltage (code 23). The controllers LEDs will display this repeating pattern.

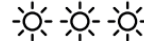
RED	YELLOW	RED	YELLOW
 (First digit)	 (2)	 (Second digit)	 (3)

Motor Controller Fault Codes

Code	Fault name	Possible Cause	Set/Clear Conditions
12	Controller over current	<ol style="list-style-type: none"> 1. External short of phase U, V or W motor connections. 2. Motor parameters are mistuned. 3. Controller defective. 4. Speed encoder noise problems. 	<p>Set: Phase current exceeded the current measurement limit.</p> <p>Clear: Cycle KSI.</p>
13	Current Sensor Fault	<ol style="list-style-type: none"> 1. Leakage to vehicle frame from phase U, V, W (Short in motor stator). 2. Controller defective. 	<p>Set: Controller current sensors have invalid offset reading.</p> <p>Clear: Cycle KSI.</p>
14	Pre charge Failed	<ol style="list-style-type: none"> 1. See Monitor menu > Battery: Capacitor Voltage. 2. External load on capacitor bank (B+ connection terminal) that prevents the capacitor bank from charging. 	<p>Set: Percentage failed to charge the capacitor bank to the KSI voltage.</p> <p>Clear: Cycle Interlock Input</p>
15	Controller Severe Under temp	<ol style="list-style-type: none"> 1. See Monitor menu » Controller: Temperature. 2. Controller is operating in an extreme environment. 	<p>Set: Heat sink temperature below -40°C.</p> <p>Clear: Bring heat sink temperature above -40°C, and cycle interlock or KSI.</p>

Motor Controller Fault Codes

Code	Fault name	Possible Cause	Set/Clear Conditions
16	Controller Severe Over temp	<ol style="list-style-type: none"> 1. See Monitor menu » Controller: Temperature. 2. Controller is operating in an extreme environment. 3. Excessive load on vehicle. 4. Improper mounting of controller. 	<p>Set: Heat sink temperature above +95°C.</p> <p>Clear: Bring heat sink temperature below +95°C, and cycle interlock or KSI.</p>
17	Severe Under voltage	<ol style="list-style-type: none"> 1. Battery Menu parameters are misadjusted. 2. Non-controller systems drain on battery. 3. Battery resistance too high. 4. Battery disconnected while driving. 5. See Monitor menu » Battery: Capacitor Voltage. 6. Blown B+ fuse or main contactor did not close. 	<p>Set: Capacitor bank voltage dropped below the Severe Under voltage limit.</p> <p>Clear: Bring capacitor voltage above Severe Under voltage limit.</p>
18	Severe Over voltage	<ol style="list-style-type: none"> 1. See Monitor menu » Battery: Capacitor Voltage. 2. Battery menu parameters are misadjusted. 3. Battery resistance too high for given regen current. 4. Battery disconnected while regen braking. 	<p>Set: Capacitor bank voltage exceeded the Severe Overvoltage limit (see page 58) with FET bridge enabled.</p> <p>Clear: Bring capacitor voltage below Severe Overvoltage limit, and then cycle KSI.</p>

Motor Controller Fault Codes

Code	Fault name	Possible Cause	Set/Clear Conditions
22	Controller Over temp Cutback	<ol style="list-style-type: none">1. See Monitor menu » Controller: Temperature.2. Controller is performance-limited at this temperature.3. Controller is operating in an extreme environment.4. Excessive load on vehicle.5. Improper mounting of controller.	<p>Set: Heat sink temperature exceeded 85°C.</p> <p>Clear: Bring heat sink temperature below 85°C.</p>
23	Under voltage Cutback	<ol style="list-style-type: none">1. Normal operation. Fault shows that the batteries need recharging. Controller is performance limited at this voltage.2. Battery parameters are misadjusted.3. Non-controller systems drain on battery.4. Battery resistance too high.5. Battery disconnected while driving.6. See Monitor menu » Battery: Capacitor Voltage.7. Blown B+ fuse or main contactor did not close.	<p>Set: Capacitor bank voltage dropped below the Under-voltage limit with the FET bridge enabled.</p> <p>Clear: Bring capacitor voltage above the Under-voltage limit.</p>

Motor Controller Fault Codes

Code	Fault name	Possible Cause	Set/Clear Conditions
24	Over voltage Cutback	<ol style="list-style-type: none"> 1. Normal operation. Fault shows that regen braking currents elevated the battery voltage during regen braking. Controller is performance limited at this voltage. 2. Battery parameters are misadjusted. 3. Battery resistance too high for given regen current. 4. Battery disconnected while regen braking. 5. See Monitor menu » Battery: Capacitor Voltage. 	<p>Set: Capacitor bank voltage exceeded the Overvoltage limit with the FET bridge enabled. Clear: Bring capacitor voltage below the Over voltage limit.</p>
28	Under voltage Cutback	<ol style="list-style-type: none"> 1. Motor temperature is at or above the programmed Temperature Hot setting, and the requested current is being cut back. 2. Motor Temperature Control Menu parameters are mistuned. See Monitor menu » Motor: Temperature and » Inputs: Analog2. 3. If the application doesn't use a motor thermistor, Temp 4. Compensation and Temp Cutback should be programmed Off. 	<p>Set: Motor thermistor input (pin 8) is at the voltage rail (0 or 10V). Clear: Bring the motor thermistor input voltage within range.</p>

Motor Controller Fault Codes

Code	Fault name	Possible Cause	Set/Clear Conditions
29	Over voltage Cutback	<ol style="list-style-type: none"> 1. Motor thermistor is not connected properly. 2. If the application doesn't use a motor thermistor, Motor Temp Sensor Enable should be programmed Off. 3. See Monitor menu » Motor: 4. Temperature and » Inputs: Analog2. 	<p>Set: Motor thermistor input (pin 8) is at the voltage rail (0 or 10V).</p> <p>Clear: Bring the motor thermistor input voltage within range.</p>
31 (Status 3,1)	Coil1 Driver Open/Short <i>ShutdownDriver1.</i>	<ol style="list-style-type: none"> 1. Open or short on driver load. 2. Dirty connector pins. 3. Bad crimps or faulty wiring. 	<p>Set: Driver 1 (pin 6) is either open or shorted. This fault can be set only when Main Enable = Off.</p> <p>Clear: Correct open or short, and cycle driver.</p>
31 (Status 3,6)	Main Open/Short <i>ShutdownMotor;</i> <i>ShutdownMain</i> <i>Contactor;</i> <i>ShutdownEMBrake;</i> <i>ShutdownThrottle;</i> <i>FullBrake.</i>	<ol style="list-style-type: none"> 1. Open or short on driver load. 2. Dirty connector pins. 3. Bad crimps or faulty wiring. 	<p>Set: Main contactor driver (pin 6) is either open or shorted. This fault can be set only when Main Enable = On.</p> <p>Clear: Correct open or short, and cycle driver.</p>

Motor Controller Fault Codes

Code	Fault name	Possible Cause	Set/Clear Conditions
36	Encoder Fault	<ol style="list-style-type: none">1. Motor encoder failure.2. Bad crimps or faulty wiring.3. See Monitor menu » Motor: Motor RPM.	Set: Motor encoder phase failure detected. Clear: Cycle KSI.
37	Motor Open	<ol style="list-style-type: none">1. Motor phase is open.2. Bad crimps or faulty wiring.	Set: Motor phase U, V, or W detected open. Clear: Cycle KSI.
38	Main Contactor Welded	<ol style="list-style-type: none">1. Main contactor tips are welded closed.2. Motor phase U or V is disconnected or open.3. An alternate voltage path (such as an external pre-charge resistor) is providing a current to the capacitor bank (B+ connection terminal).	Set: Just prior to the main contactor closing, the capacitor bank voltage (B+ connection terminal) was loaded for a short time and the voltage did not discharge. Clear: Cycle KSI

Motor Controller Fault Codes

Code	Fault name	Possible Cause	Set/Clear Conditions
39	Main Contactor Did Not Close	<ol style="list-style-type: none">1. Main contactor did not close.2. Main contactor tips are oxidized, burned or not making good contact.3. External load on capacitor bank (B+ connection terminal) that prevents capacitor bank from charging.4. Blown B+ fuse.	Set: With the main contactor commanded closed, the capacitor bank voltage (B+ connection terminal) did not charge to B+. Clear: Cycle KSI.
40	Throttle Wiper High	<ol style="list-style-type: none">1. See Monitor menu » Inputs: Throttle Pot.2. Throttle pot wiper voltage too high.	Set: Throttle pot wiper (pin 16) voltage is higher than the high fault threshold, (can be changed with the VCL function: Setup_Pot_Faults()). Clear: Bring throttle pot wiper voltage below the fault threshold.

Motor Controller Fault Codes

Code	Fault name	Possible Cause	Set/Clear Conditions
40	Throttle Wiper Low	<ol style="list-style-type: none">1. See Monitor menu » Inputs: Throttle Pot.2. Throttle pot wiper voltage too low.	<p>Set: Throttle pot wiper (pin 16) voltage is lower than the low fault threshold (can be changed with the VCL function Setup_Pot_Faults()).</p> <p>Clear: Bring throttle pot wiper voltage above the fault threshold.</p>
73	Stall Detected	<ol style="list-style-type: none">1. Stalled motor.2. Motor encoder failure.3. Bad crimps or faulty wiring.4. Problems with power supply for the motor encoder.5. See Monitor menu » Motor: Motor RPM.	<p>Set: No motor encoder movement detected. Clear: Either cycle KSI or detect valid motor encoder signals while operating in LOS mode and return Throttle Command = 0 and Motor RPM = 0.</p>

Motor Controller Fault Codes

Code	Fault name	Possible Cause	Set/Clear Conditions
93	Encoder LOS (Limited Operating Strategy)	<ol style="list-style-type: none">1. Limited Operating Strategy (LOS) control mode has been activated, as a result of either an Encoder Fault (Code 36) or a Stall Detect Fault (Code 73).2. Motor encoder failure.3. Bad crimps or faulty wiring.4. Vehicle is stalled.	Set: Encoder Fault (Code 36) or Stall Detect Fault (Code 73) was activated, and Brake or Interlock has been applied to activate LOS control mode, allowing limited motor control. Clear: Cycle KSI or, if LOS mode was activated by the Stall Fault, clear by ensuring encoder senses proper operation, Motor RPM = 0, and Throttle Command = 0.



Troubleshooting: Belts

Symptom	Diagnosis	Possible Remedy
Unusual noise	<p>Misaligned drive.</p> <p>Too low or high belt tension. Backside idler.</p> <p>Worn sprocket.</p> <p>Bent guide flange.</p> <p>Belt speed too high.</p> <p>Incorrect belt profile for the sprocket (i.e., GT® etc.).</p> <p>Subminimal diameter.</p> <p>Excess load.</p>	<p>Correct alignment.</p> <p>Adjust tension to recommended value.</p> <p>Use inside idler</p> <p>Replace sprocket.</p> <p>Replace sprocket/flange.</p> <p>Redesign drive.</p> <p>Use proper Gates PowerGrip® GT®3 belt/sprocket.</p> <p>Redesign drive using larger diameters.</p> <p>Redesign drive for increased capacity.</p>
Tension loss	<p>Weak support structure.</p> <p>Excessive sprocket wear.</p> <p>Fixed (nonadjustable) centers. Excessive debris.</p> <p>Excessive load.</p> <p>Subminimal diameter.</p> <p>Belt, sprockets, or shafts running too hot.</p> <p>Unusual belt degradation, such as softening or melting.</p>	<p>Reinforce the structure.</p> <p>Use alternate sprocket material.</p> <p>Use inside idler for belt adjustment.</p> <p>Protect drive.</p> <p>Redesign drive for increased capacity.</p> <p>Redesign drive using larger diameters.</p> <p>Check for conductive heat transfer from prime mover. Reduce ambient drive temperature to 180°F maximum.</p>

Troubleshooting: Belts

Symptom	Diagnosis	Possible Remedy
Belt tracking	Belt running partly off un-flanged sprocket centers exceed 8 times small sprocket diameter and the large sprocket is not flanged. Excessive belt edge wear	Correct alignment. Correct parallel alignment to set belt to track on both sprockets. Correct alignment
Flange failure 	Belt forcing flanges off	Correct alignment or properly secure flange to sprocket



Troubleshooting: Belts

Symptom	Diagnosis	Possible Remedy
<p>Excessive belt edge wear</p> 	<p>Damage due to handling. Flange damage. Belt too wide. Belt tension too low. Rough flange surface finish. Improper tracking. Belt hitting drive guard or bracketry.</p>	<p>Follow proper handling instructions. Repair flange or replace sprocket. Use proper width sprocket. Adjust tension to recommended value. Replace or repair flange (to eliminate abrasive surface). Correct alignment. Remove obstruction or use inside idler.</p>
<p>Tooth shear</p> 	<p>Excessive shock loads. Less than 6 teeth-in-mesh. Extreme sprocket runout. Worn sprocket. Backside idler. Incorrect belt profile for the sprocket (i.e., GT®, etc.). Misaligned drive. Insufficient belt tension.</p>	<p>Redesign drive for increased capacity. Redesign drive Replace sprocket. Replace sprocket. Use inside idler Use proper Gates PowerGrip® GT®3 belt/sprocket. Correct alignment. Adjust tension to recommended value.</p>

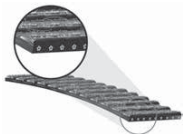
Troubleshooting: Belts

Symptom	Diagnosis	Possible Remedy
<p data-bbox="124 234 316 288">Premature tooth wear</p> 	<p data-bbox="352 234 766 809">Too low or high belt tension. Belt running partly off un-flanged sprocket. Misaligned drive. Incorrect belt profile for the sprocket (i.e., GT®, etc.). Worn sprocket. Rough sprocket teeth. Damaged sprocket. Sprocket not to dimensional specification. Belt hitting drive bracketry or other structure. Excessive load Insufficient hardness of sprocket material. Excessive debris. Cocked bushing/sprocket assembly.</p>	<p data-bbox="802 234 1353 809">Adjust tension to recommended value. Correct alignment. Correct alignment. Use proper Gates PowerGrip® GT®3 belt/sprocket. Replace sprocket. Replace sprocket. Replace sprocket. Replace sprocket. Remove obstruction or use inside idler. Redesign drive for increased capacity. Use a more wear-resistant material. Protect belt. Install bushing per instructions.</p>

Troubleshooting: Belts

Symptom	Diagnosis	Possible Remedy
<p>Tensile break</p> 	<p>Excessive shock load. Subminimal diameter. Improper belt handling and storage prior to installation. Debris or foreign object in drive. Extreme sprocket runout. Too low or high belt tension.</p>	<p>Redesign drive for increased capacity. Redesign drive using larger diameters. Follow proper handling and storage procedures.</p> <p>Protect drive. Replace sprocket. Adjust tension to recommended level.</p>
<p>Unusual sprocket wear</p> 	<p>Sprocket has too little wear resistance (i.e., plastic, aluminum, softer metals). Misaligned drive. Excessive debris. Excessive load. Too high, too low belt tension. Incorrect belt profile (i.e., GT, etc.).</p>	<p>Use alternate sprocket material.</p> <p>Correct alignment. Protect drive. Redesign drive for increased capacity. Adjust tension to recommended value. Use proper Gates PowerGrip GT®3 belt/sprocket.</p>

Troubleshooting: Belts

Symptom	Diagnosis	Possible Remedy
<p>Belt cracking</p> 	<p>Subminimal diameter. Backside idler. Extreme low temperature startup. Extended exposure to harsh chemicals. Cocked bushing/sprocket assembly.</p>	<p>Redesign drive using larger diameters. Use inside idler. Preheat drive environment.</p> <p>Protect drive.</p> <p>Install bushing per instructions.</p>
<p>Excessive temperature (belt, bearing, housing, shafts, etc.)</p>	<p>Misaligned drive. Too low or too high belt tension. Incorrect belt profile (i.e., GT, etc.).</p>	<p>Correct alignment. Adjust tension to recommended value. Use proper Gates PowerGrip GT®3 belt/sprocket.</p>
<p>Vibration</p>	<p>Incorrect belt profile for the sprocket (i.e. GT, etc.). Too low or too high belt . Bushing or key loose.</p>	<p>Use proper Gates PowerGrip GT®3 belt/sprocket.</p> <p>Adjust tension to recommended value. Check and reinstall per instructions.</p>

Troubleshooting: Roller

Roller will not move one or either way, check:

- Batteries are not charged.
- Ignition is on.
- Belt is correctly fitted and tensioned.
- Sprockets are not worn or slipping on the shaft.
- Foot control is operating correctly.
- For sheared sprocket keys.
- Rubber coupling broken

Roller will not steer, check:

- Woodruff key is in place and not sheared.
- Rod ends are connected to smoothing roller head and the steering arm.
- Rod ends are not broken or seized.
- Swivel bearing on connecting the smoothing roller head to the pivot beam, have not seized.
- Connecting rods are in place and serviceable.

Roller has excessive vibration, check

- Disconnect engine-to- transmission and isolate the drive chain to determine whether the problem is in the engine or in the transmissions.
- If engine is at fault, contact your nearest engine agent for rectification.
- If the transmission is at fault, repair or replace as necessary, or seek professional advice from a local Eaton Service Centre.
- Any out of alignment between engine and transmission.
- For damaged engine and transmission couplings

Troubleshooting: Roller

Smoothing rollers seized, check

- Bearings are OK and not rough or seized.
- Replace if necessary.
- Accumulated dry debris is not locking the smoothing rollers.

Rubber drive roller will not rotate, check

- Roller shaft end bearings have not seized.
- Broken chain
- Slipping sprockets
- The park brake is not locked on

